

LEAD CONNECTION	
240V	BK-LINE
OTHER BK TO BR TIED & ISOLATED	
YE & WH TIED AND ISOLATED	
BU-LINE	
120V	BK-LINE
OTHER BK TO BR & WH TIED AND ISOLATED	
YE & BU TIED - LINE	

(3) SLOTS EQUI-SPACED ON 4.187 P.C.D. AS SHOWN

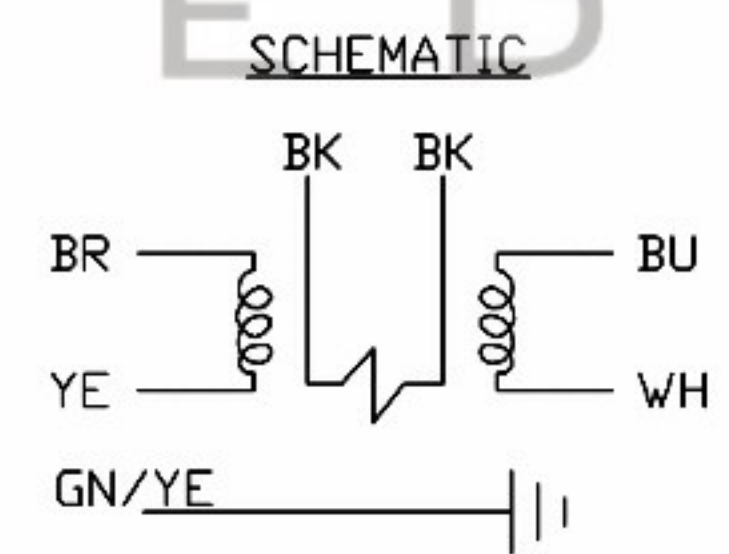

SPECIFICATION					
Motor	SP	Speed (RPM)	2500	Bearings	SLEEVE
Voltage (V)	120/240	Motor Protection	Th. Prot.	Weight (Kg)	
Frequency (Hz)	50	Insulation Class	B	Air Volume (M³/h)	
Power In/Out (W)	18	Protection Class	IP42	Noise Level (dBA)	
Current (A)	0.8/0.4	Temp. Range		Capacitor (Mf)	16.0

**POLE STAR**  
PRODUCTS LIMITED

POLE STAR PRODUCTS LIMITED	
Product Code	<b>33TD18-1</b>
Projection Angle	± 3°
Scale:	A4
Sheet:	1 of