

POLE STAR PRODUCTS LIMITED

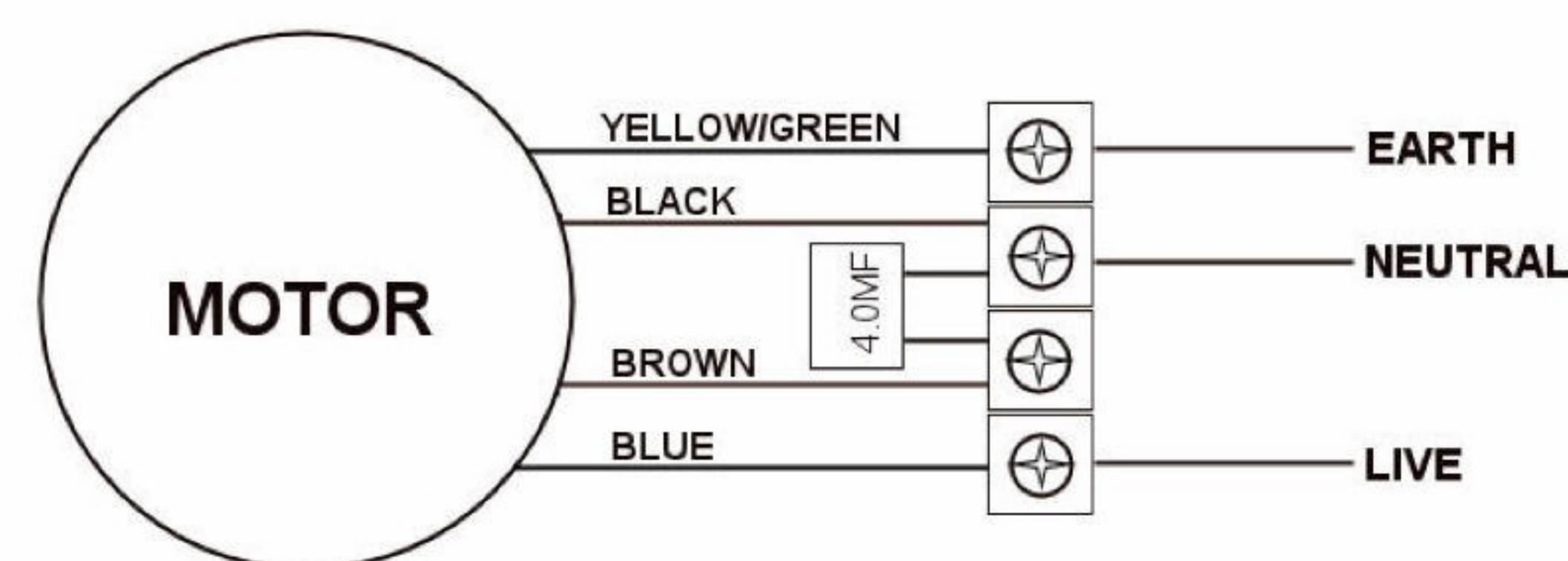
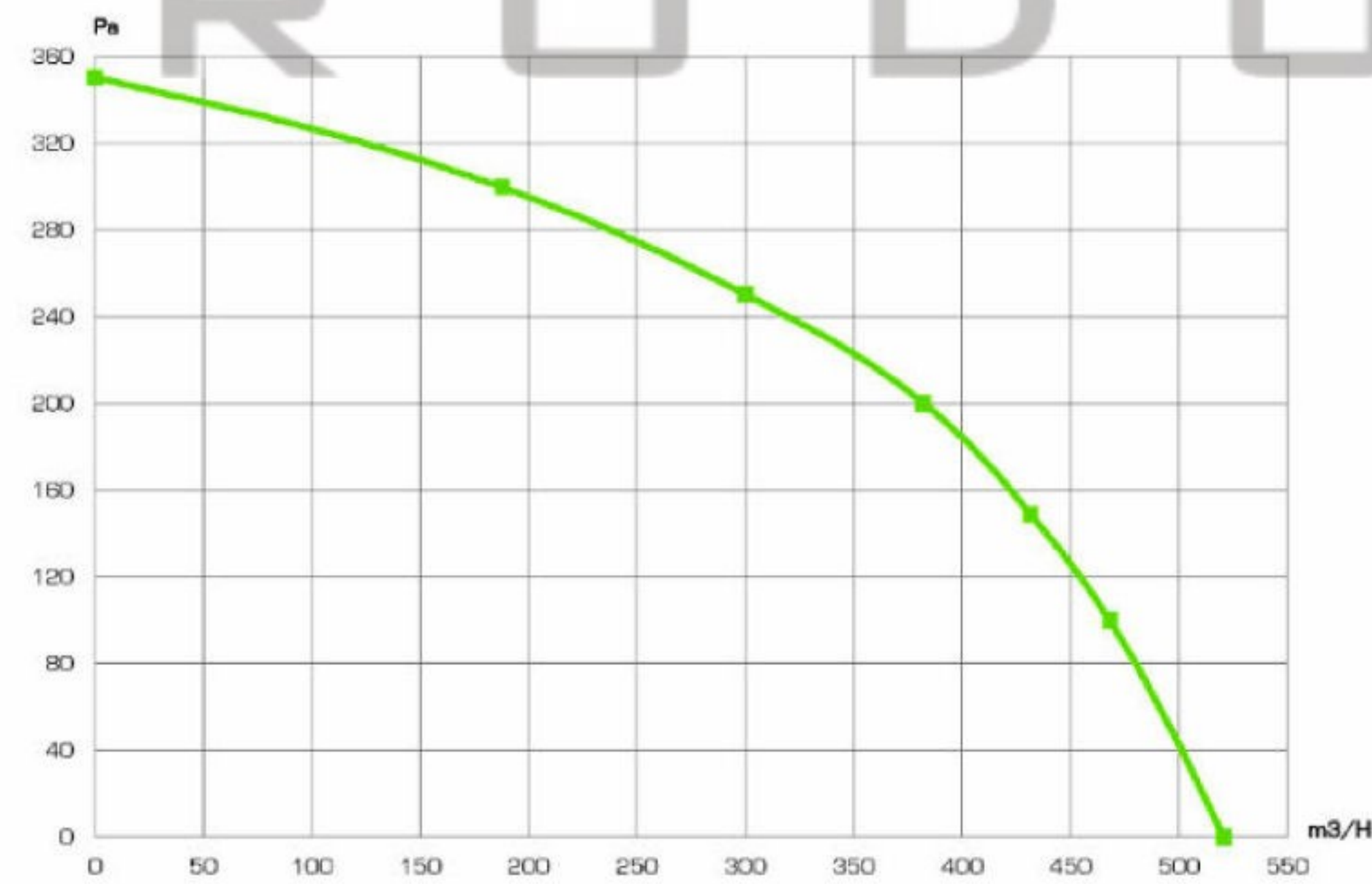

SPECIFICATION					
Motor	PSC	Speed (RPM)	1683	Bearings	Ball
Voltage (V)	230/240	Motor Protection	Th.Prot	Weight (Kg)	3.7
Frequency (Hz)	50/60	Insulation Class	B	Air Volume (M³/h)	522
Power In/Out (W)	145.5	Protection Class	IP42	Noise Level (dBA)	
Current (A)	0.65	Capacitor (Mf)	4.0	Pressure (Pa)	0

**POLE STAR**  
PRODUCTS LIMITED

POLE STAR PRODUCTS LIMITED	
Product Code	<b>CB133.126-2</b>
Projection Angle ± 3°	
	A4
	Scale:
	Sheet: 1 of