

Model: CB146.180-1  
 AC 230V~50Hz  
 320W 1.4A 1250rpm  
 Cap.:8uF/450V  
 Class:F

SINGLE-PHASE WIRING DIAGRAM

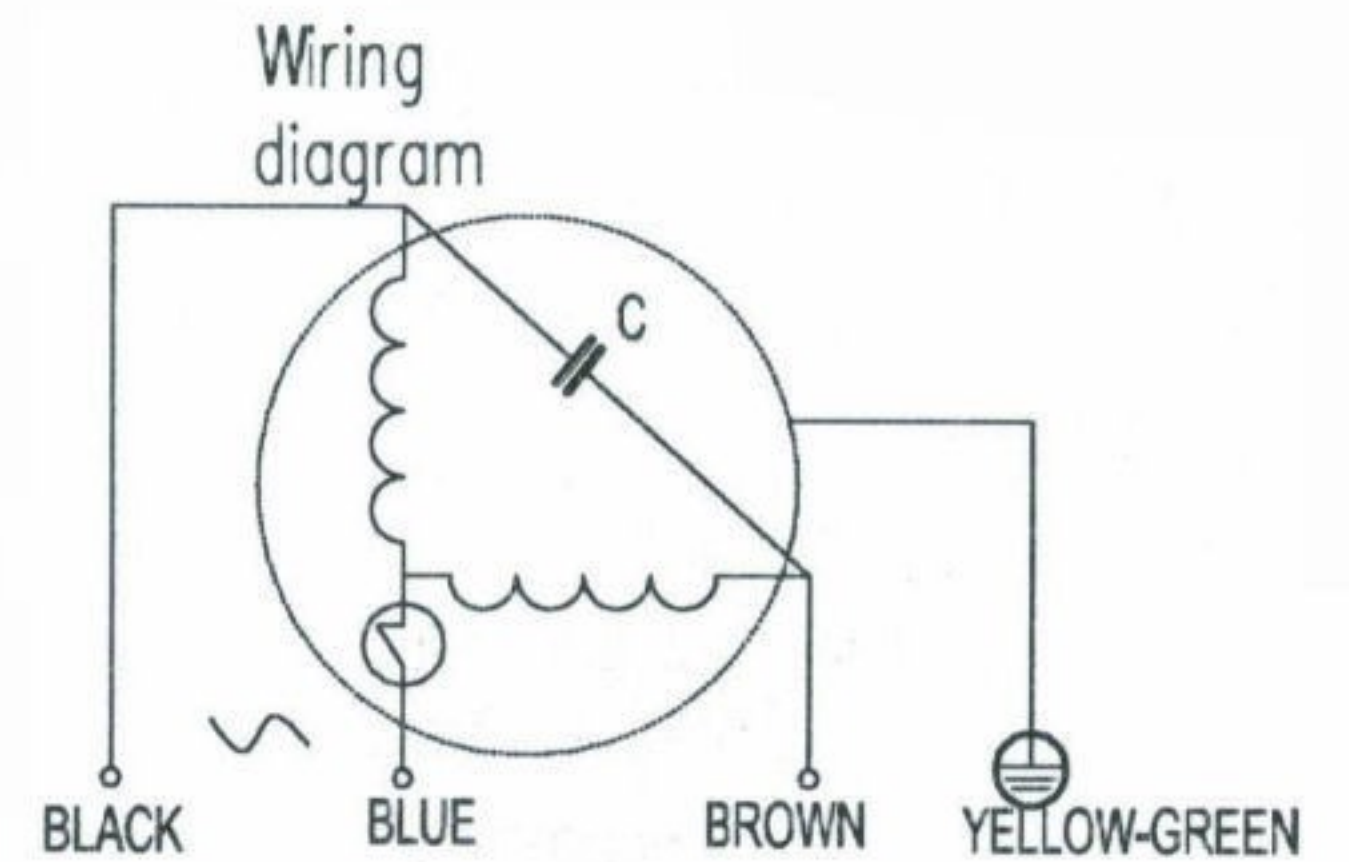
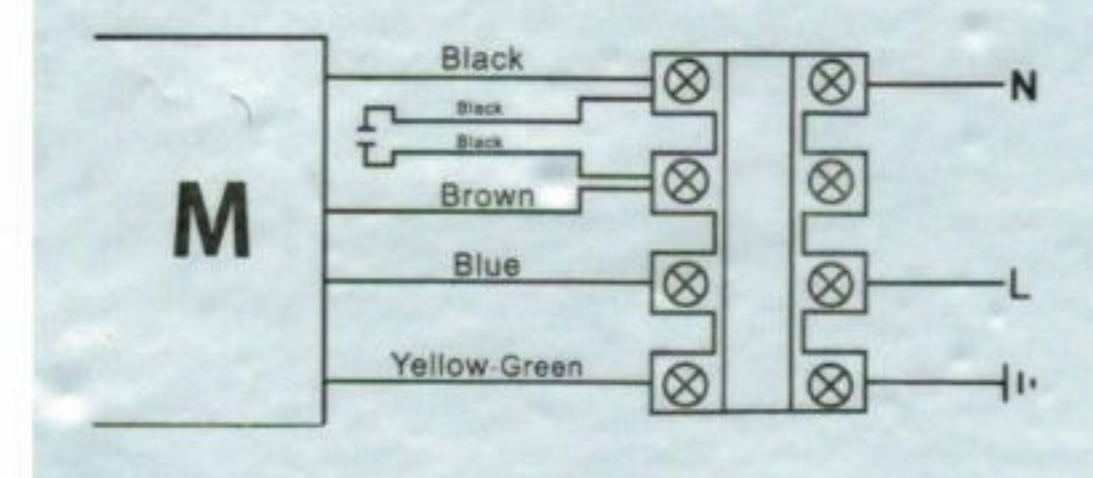

SPECIFICATION					
Motor	PSC	Speed (RPM)	1250	Bearings	Ball
Voltage (V)	230	Motor Protection	Th.Prot.	Weight (Kg)	3.8
Frequency (Hz)	50	Insulation Class	F	Impeller (mm)	146x180
Power In/Out (W)	320	Protection Class	IP42	Air flow (M <sup>2</sup> /h)	1000
Current (A)	1.4	Capacitor (MF)	8.0	Noise (dB(A))	67

**POLE STAR**  
 PRODUCTS LIMITED

POLE STAR PRODUCTS LIMITED	
Product Code	<b>CB146.180-1</b>
Projection Angle	± 3°
Scale:	A4
Sheet:	1 of 1