

Accessories: DDF10/8 (Flange)

Accessories: DD10F (Mounting Feet)

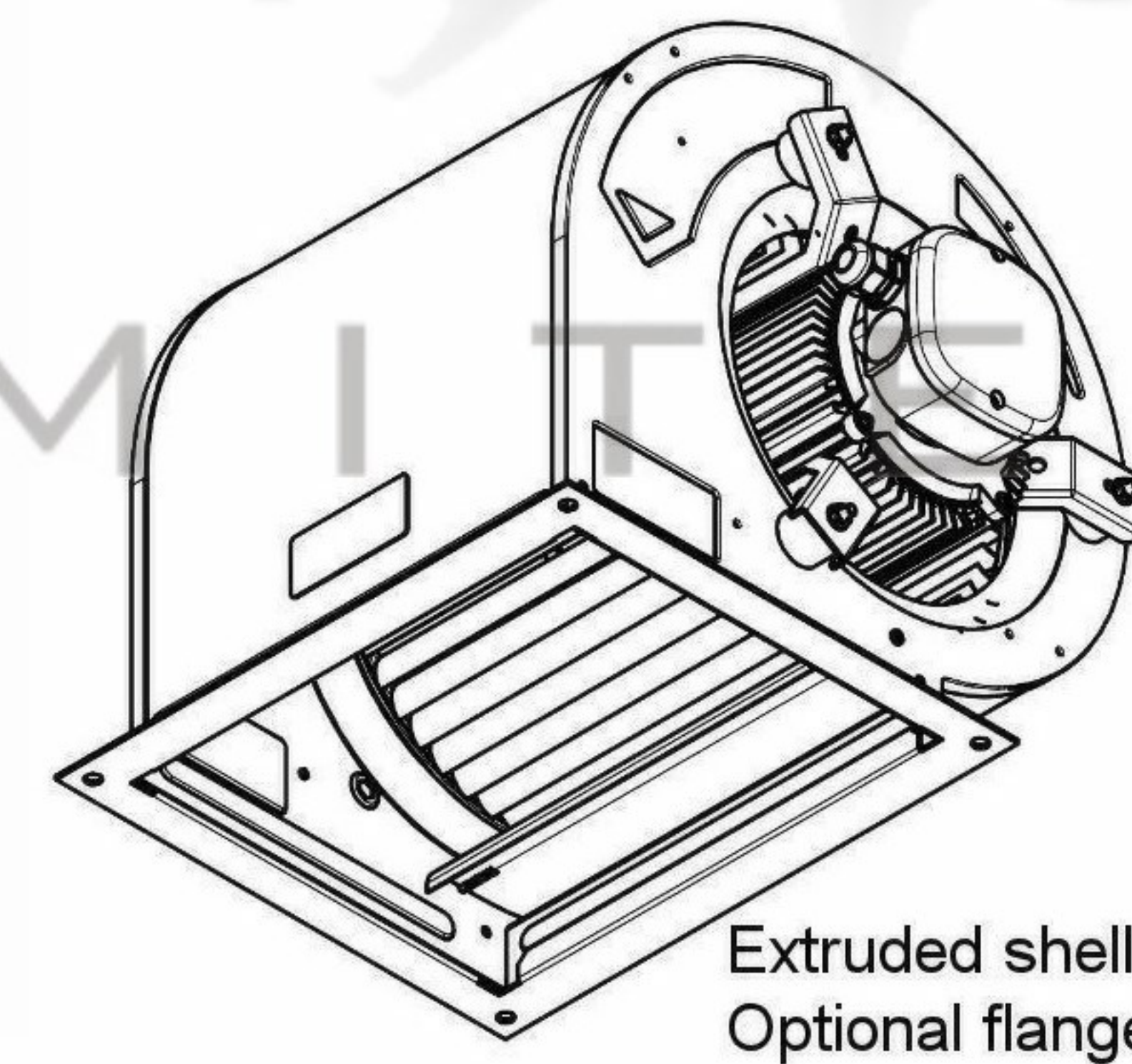
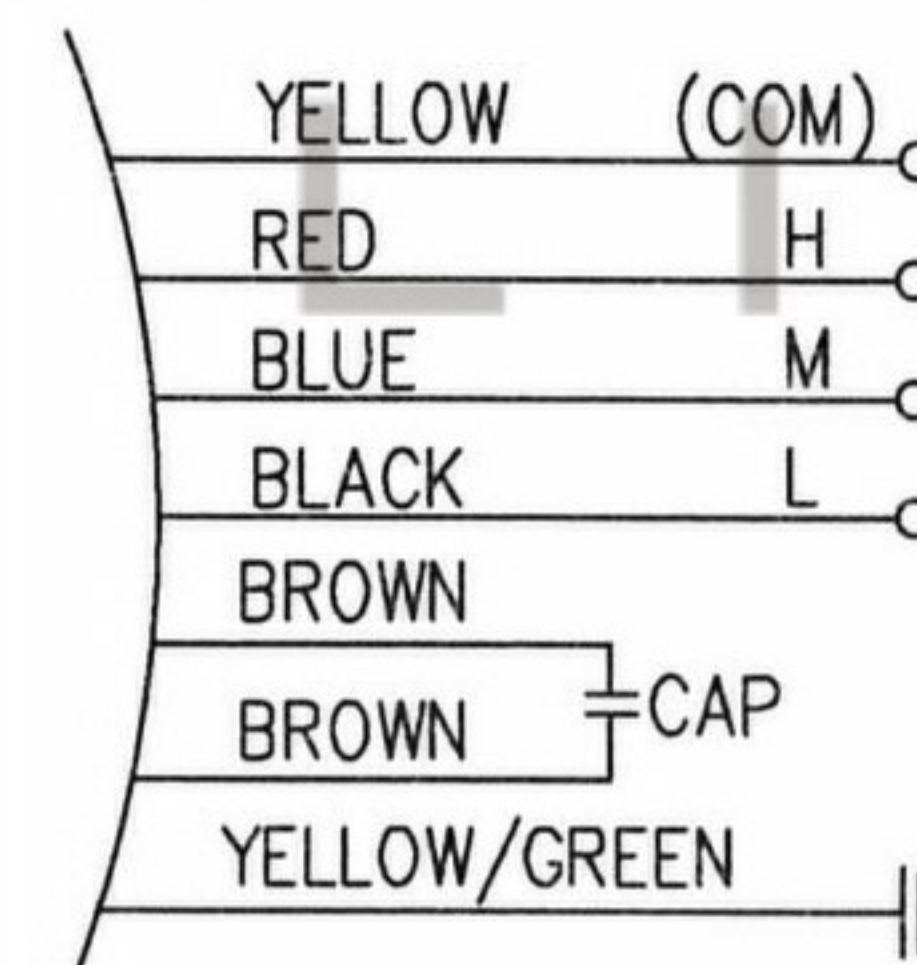
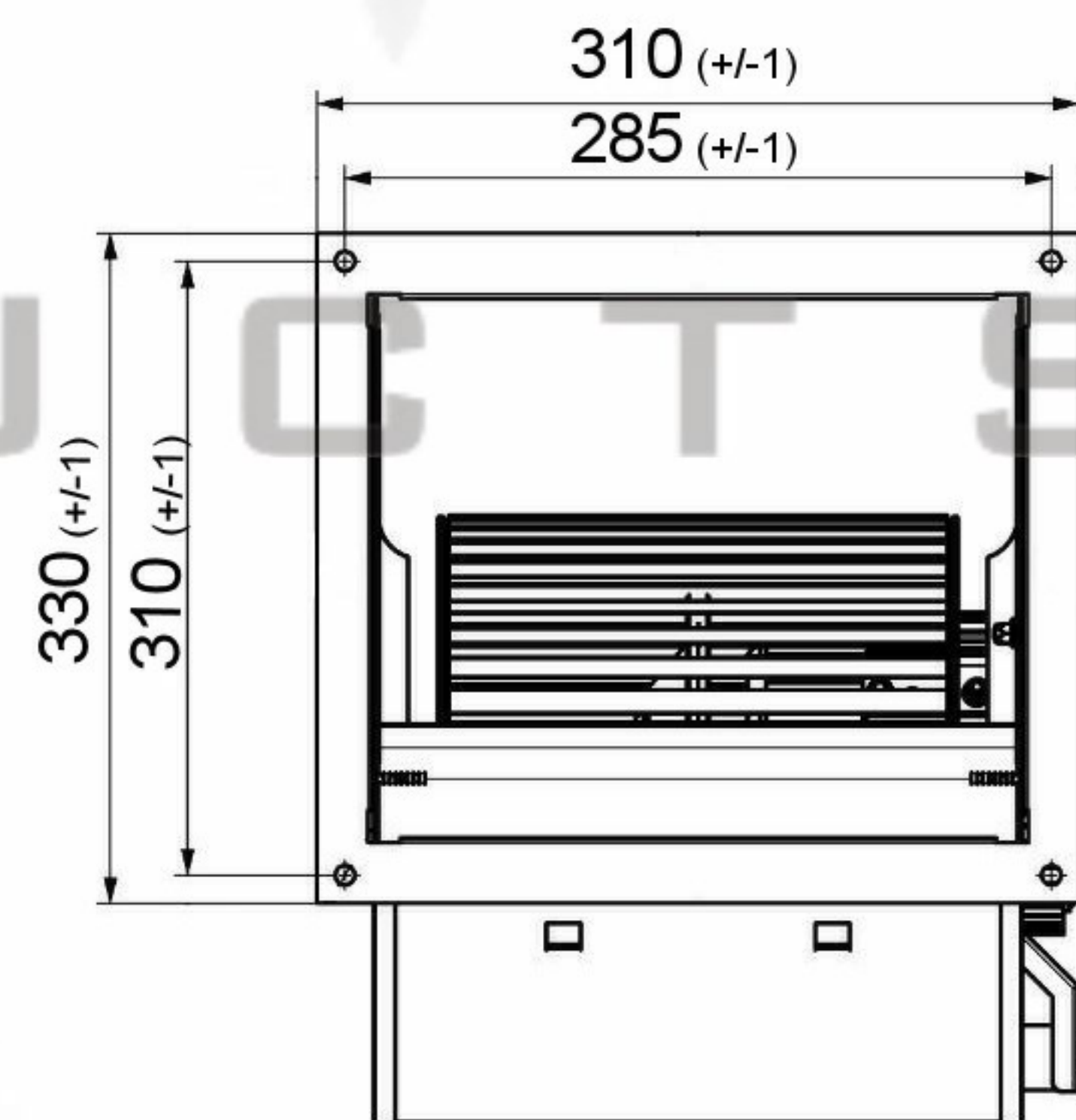
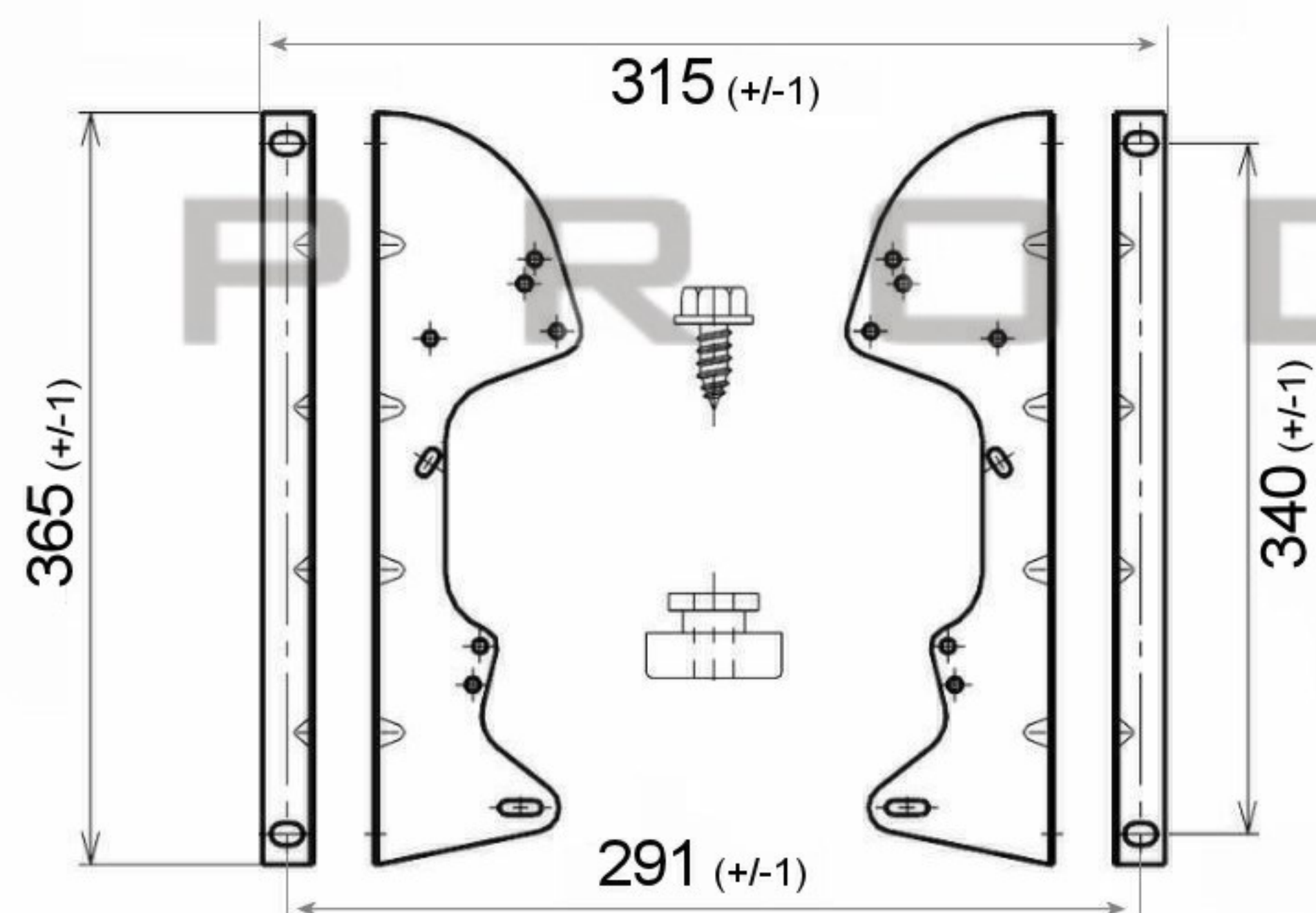

Extruded shell motor depicted
Optional flange fitted

SPECIFICATION					
Motor	PSC	Speed (RPM)	850	Bearings	Ball
Voltage (V)	220/240	Motor Protection	Th.Prot	Weight (Kg)	15.0
Frequency (Hz)	50/60	Insulation Class	B	Air Volume (M ³ /h)	1900/2350 2700
Power In/Out (W)	245	Protection Class	IP42	Noise Level (dBA)	
Current (A)	1.8	Capacitor (Mf)	10	Pressure (Pa)	49

POLE STAR
PRODUCTS LIMITED

POLE STAR PRODUCTS LIMITED	
Product Code	DD10/8-S245/3V-1
Projection Angle	± 3°
	A4
	Scale:
	Sheet: 1 of