

Accessories: DD12F (Mounting Feet)

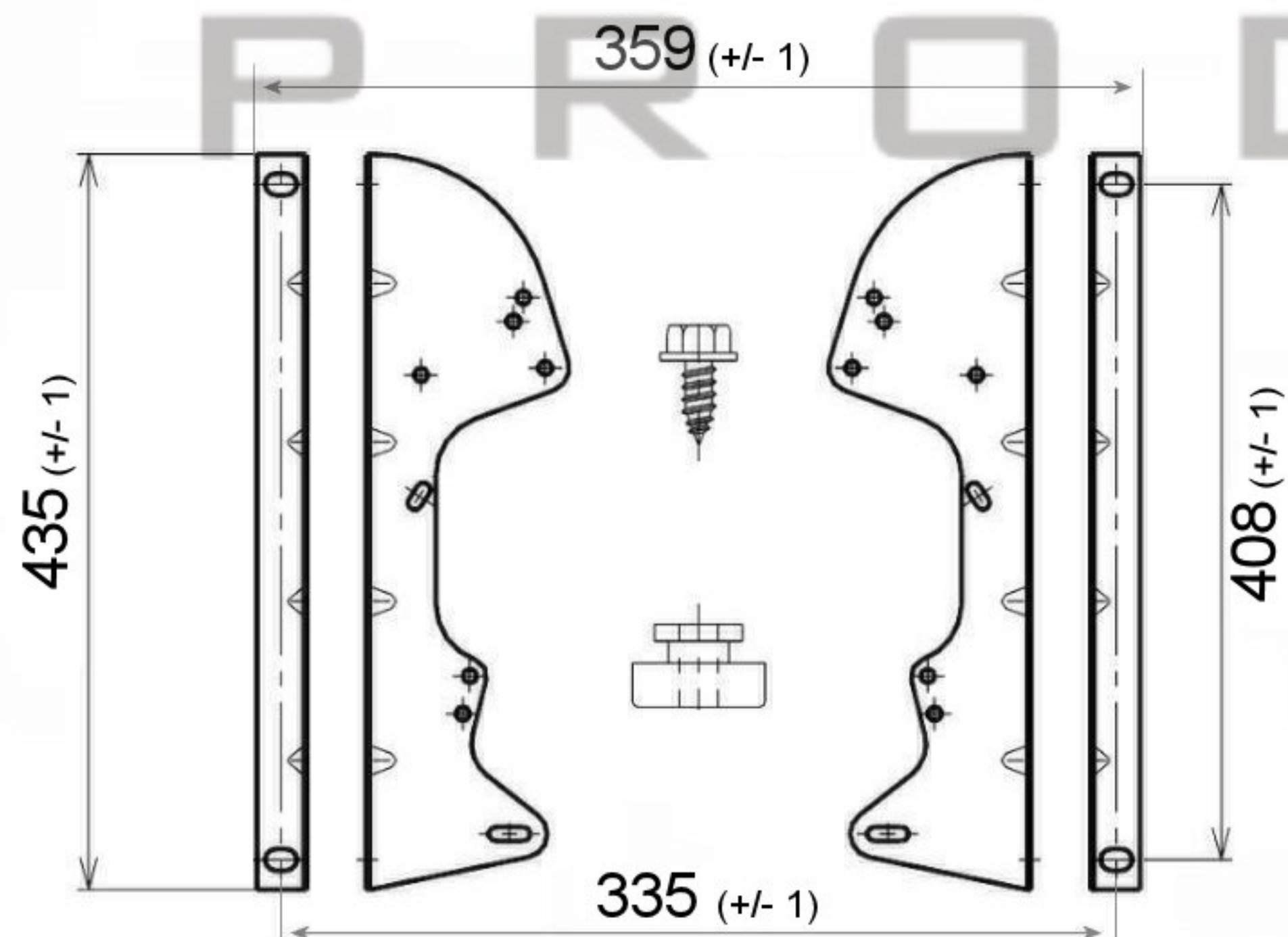

Accessories: DDF12/9 (Mounting Flange)

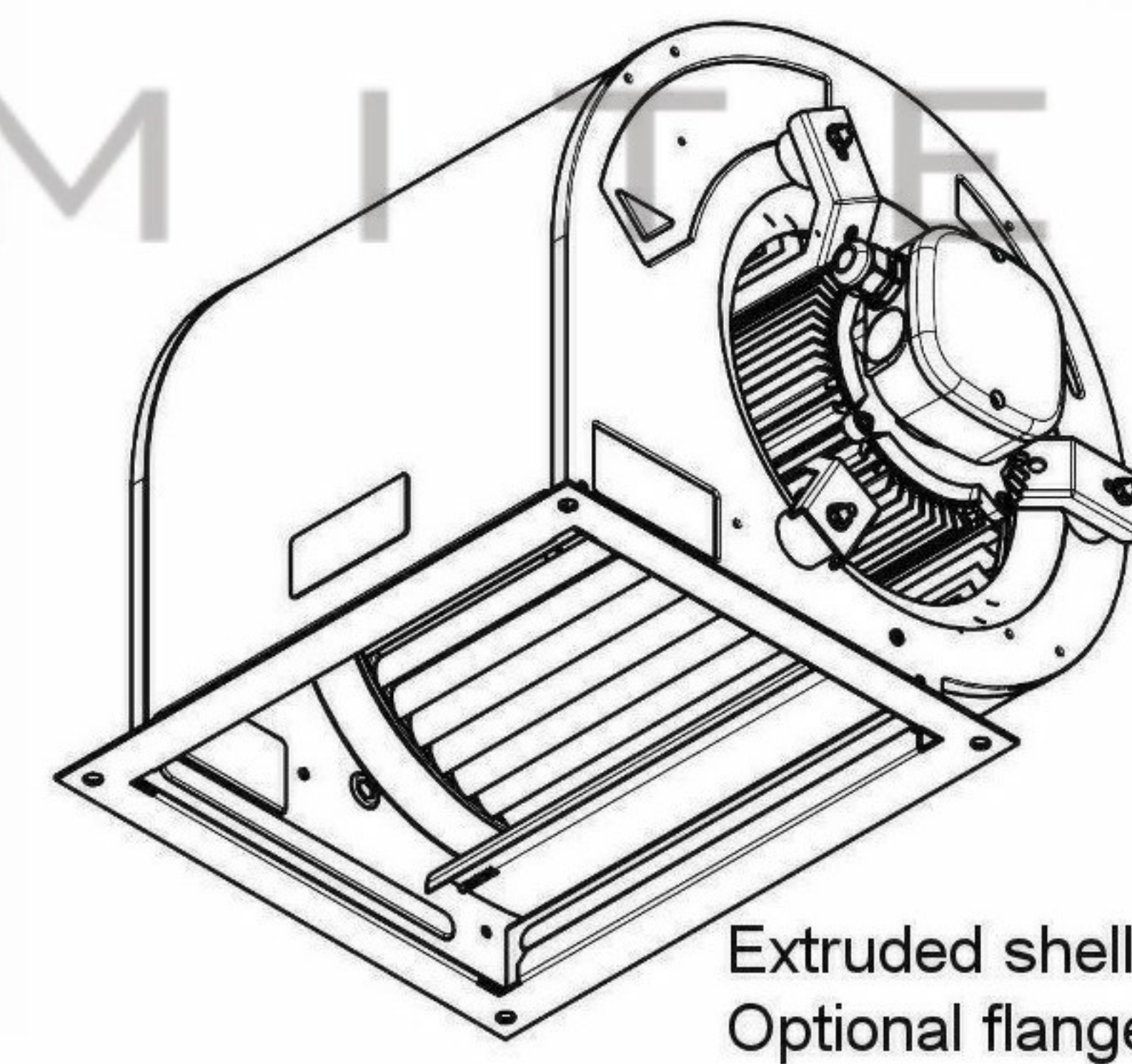
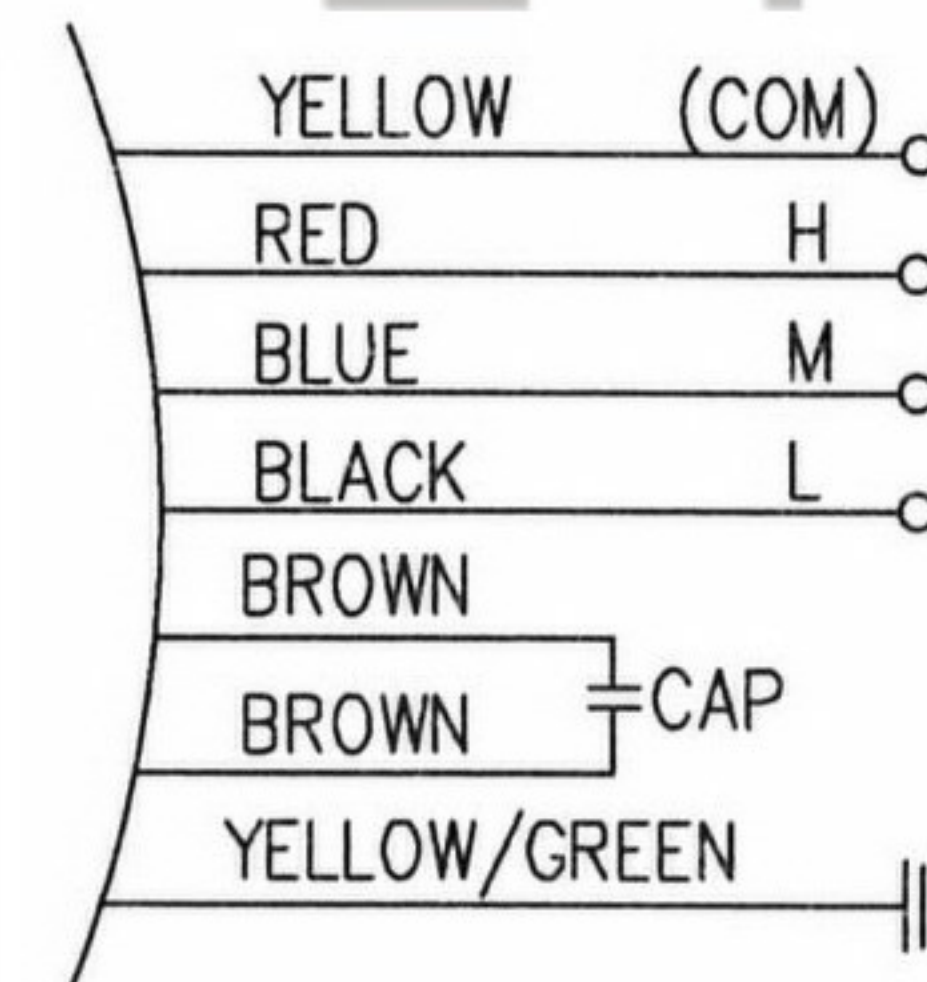
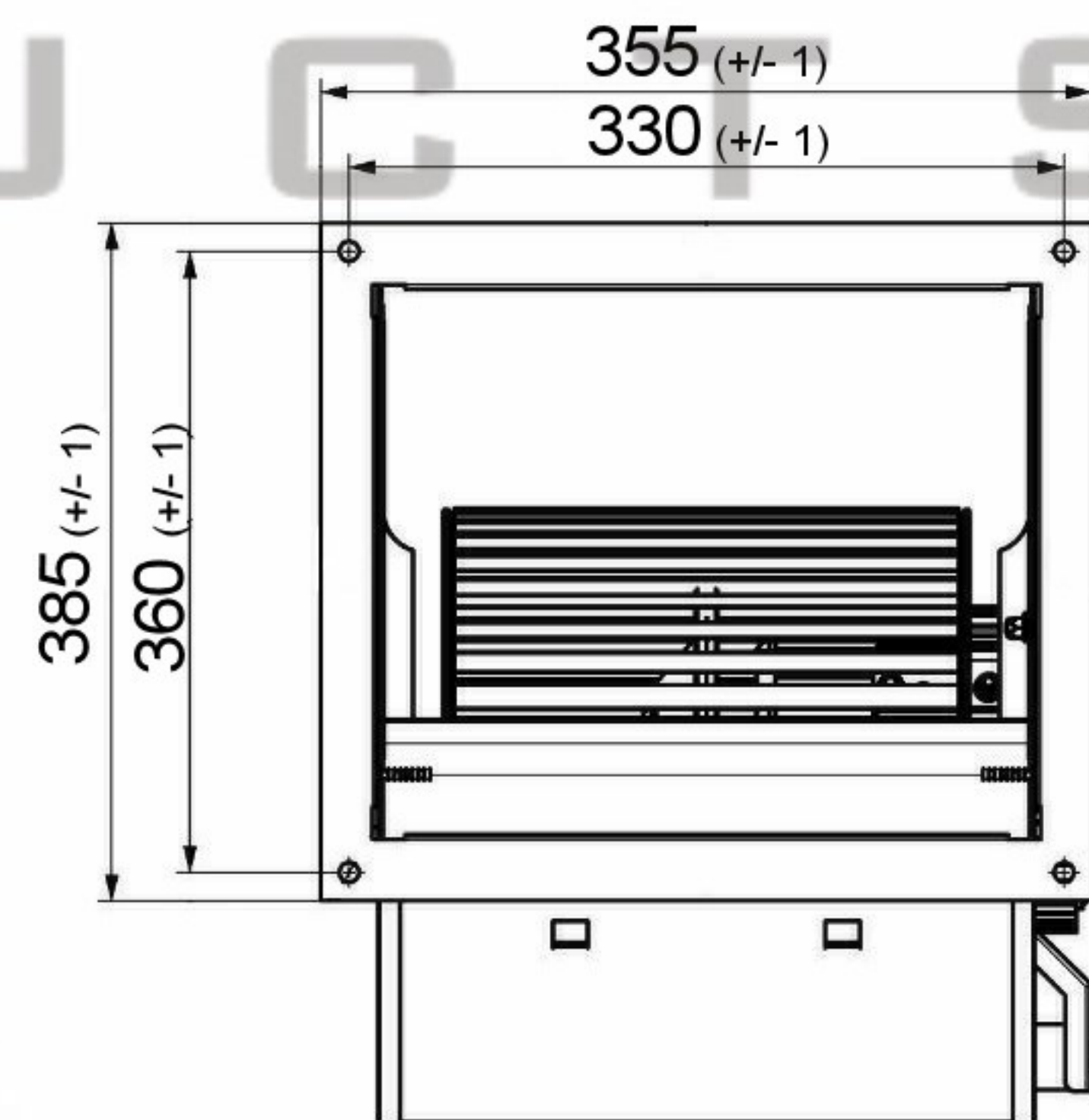

Extruded shell motor depicted
Optional flange fitted

SPECIFICATION					
Motor	PSC	Speed (RPM)	700/800 900	Bearings	Ball
Voltage (V)	220/240	Motor Protection	Th.Prot	Weight (Kg)	
Frequency (Hz)	50/60	Insulation Class	B	Air Volume (M ³ /h)	
Power In/Out (W)		Protection Class	IP42	Noise Level (dBA)	
Current (A)		Capacitor (Mf)		Pressure (Pa)	

POLE STAR
PRODUCTS LIMITED

POLE STAR PRODUCTS LIMITED	
Product Code	DD12/9-S735/3V-1
Projection Angle	± 3°
	A4
Scale:	Sheet: 1 of