

**Accessories - DD7F (Mounting Feet)**

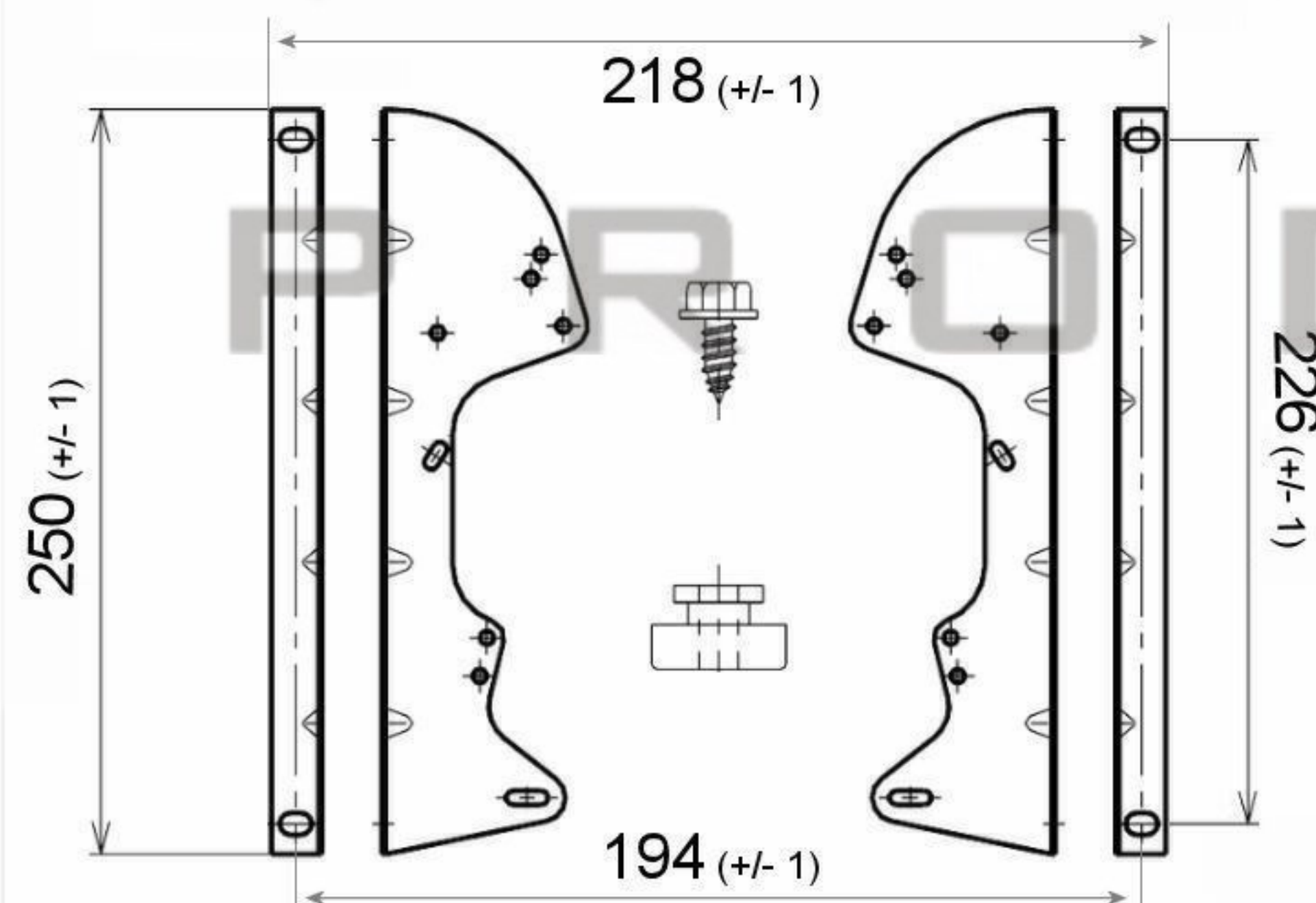

**Accessories - DDF7/5 (Flange)**

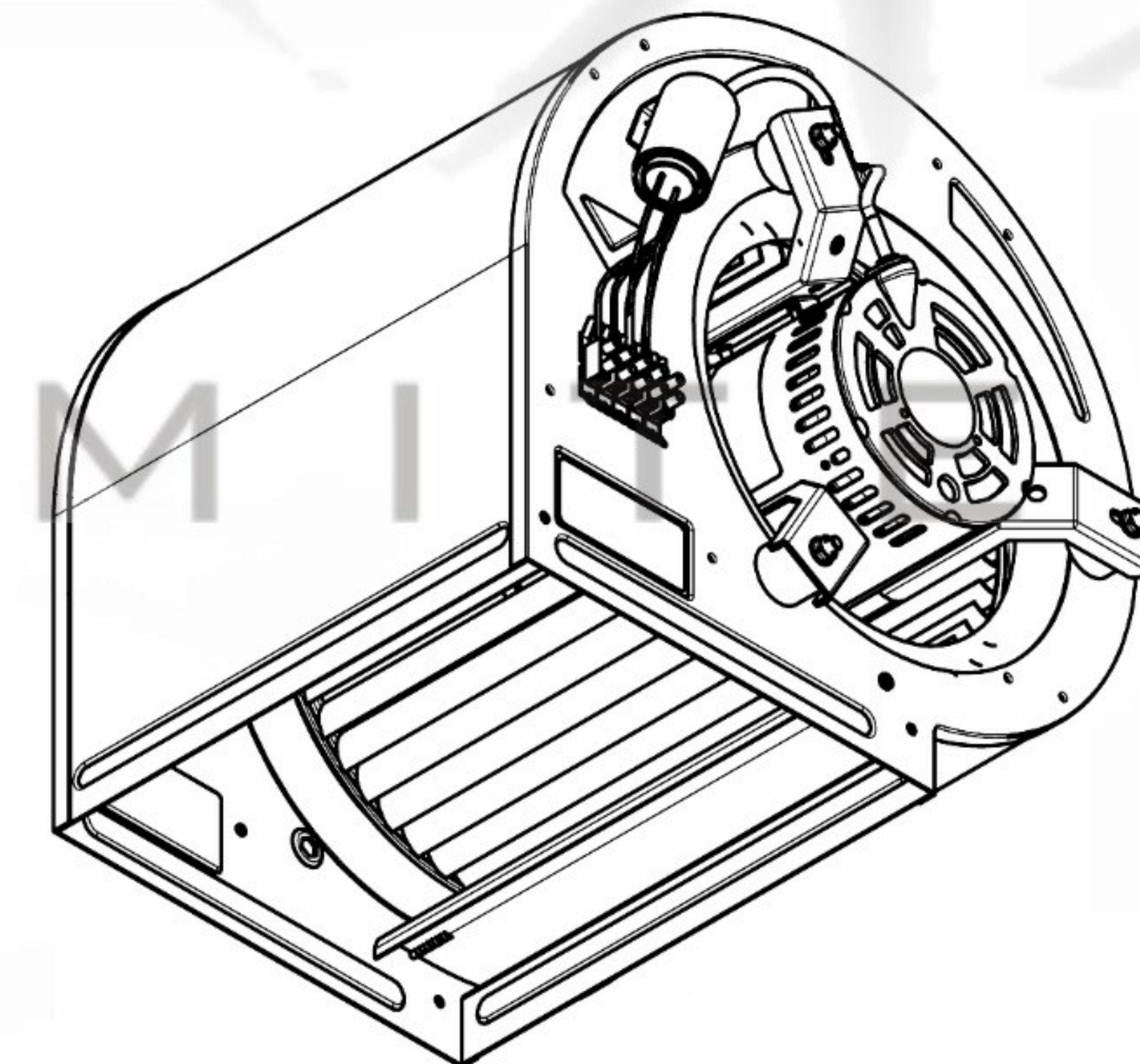
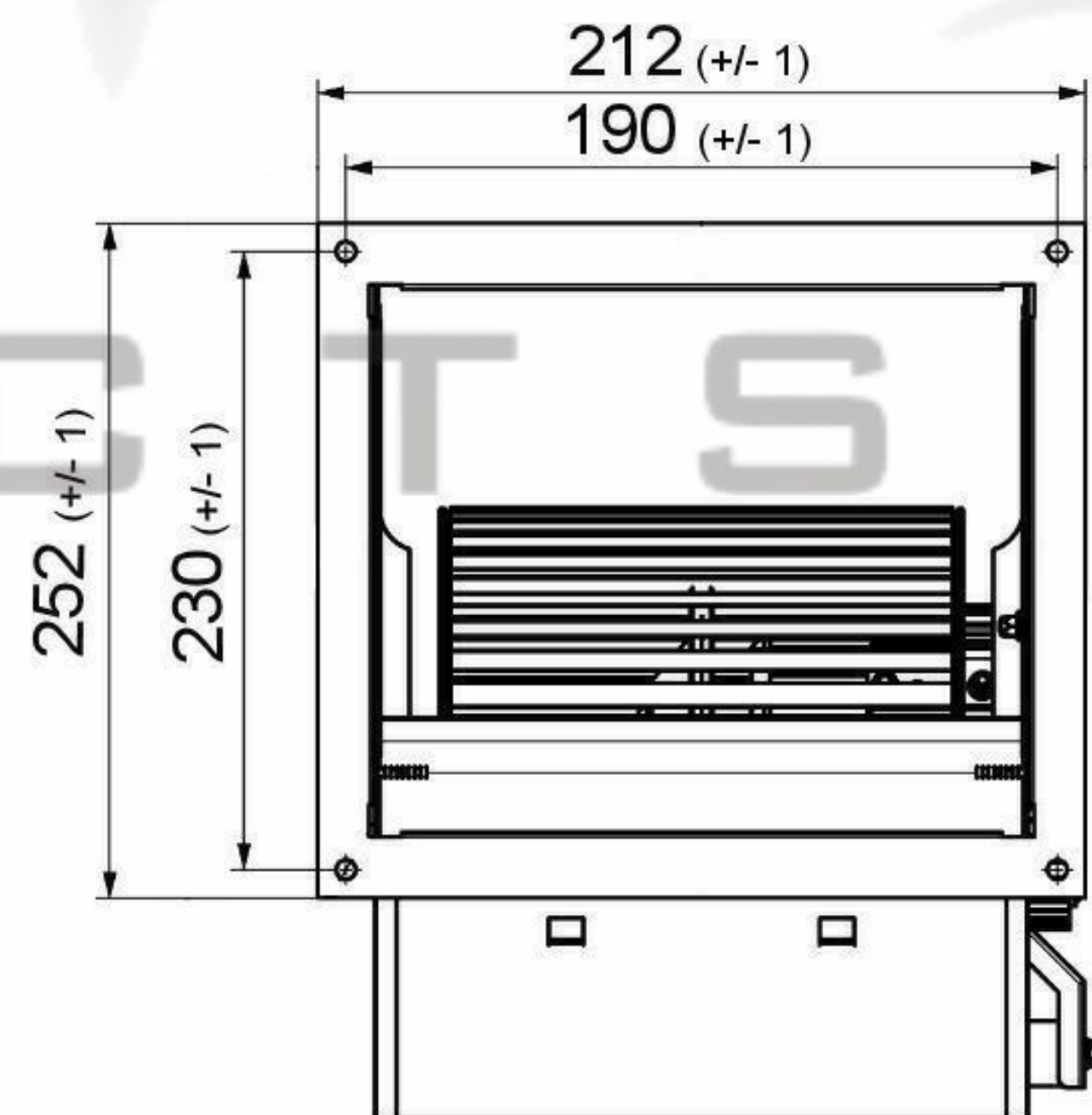

SPECIFICATION					
Motor	PSC	Speed (RPM)	1250	Bearings	Ball
Voltage (V)	230/240	Motor Protection	Th.Prot	Weight (Kg)	7.5
Frequency (Hz)	50/60	Insulation Class	B	Air Volume (M³/h)	830
Power In/Out (W)	50	Protection Class	IP42	Noise Level (dBA)	
Current (A)	0.65	Capacitor (Mf)	2.5	Pressure (Pa)	41

**POLE STAR**  
PRODUCTS LIMITED

POLE STAR PRODUCTS LIMITED	
Product Code	
<b>DD7/5-F50/1V-1</b>	
Projection Angle	A4
± 3°	Scale:
	Sheet: 1 of

