

Accessories - DD7F (Mounting Feet)

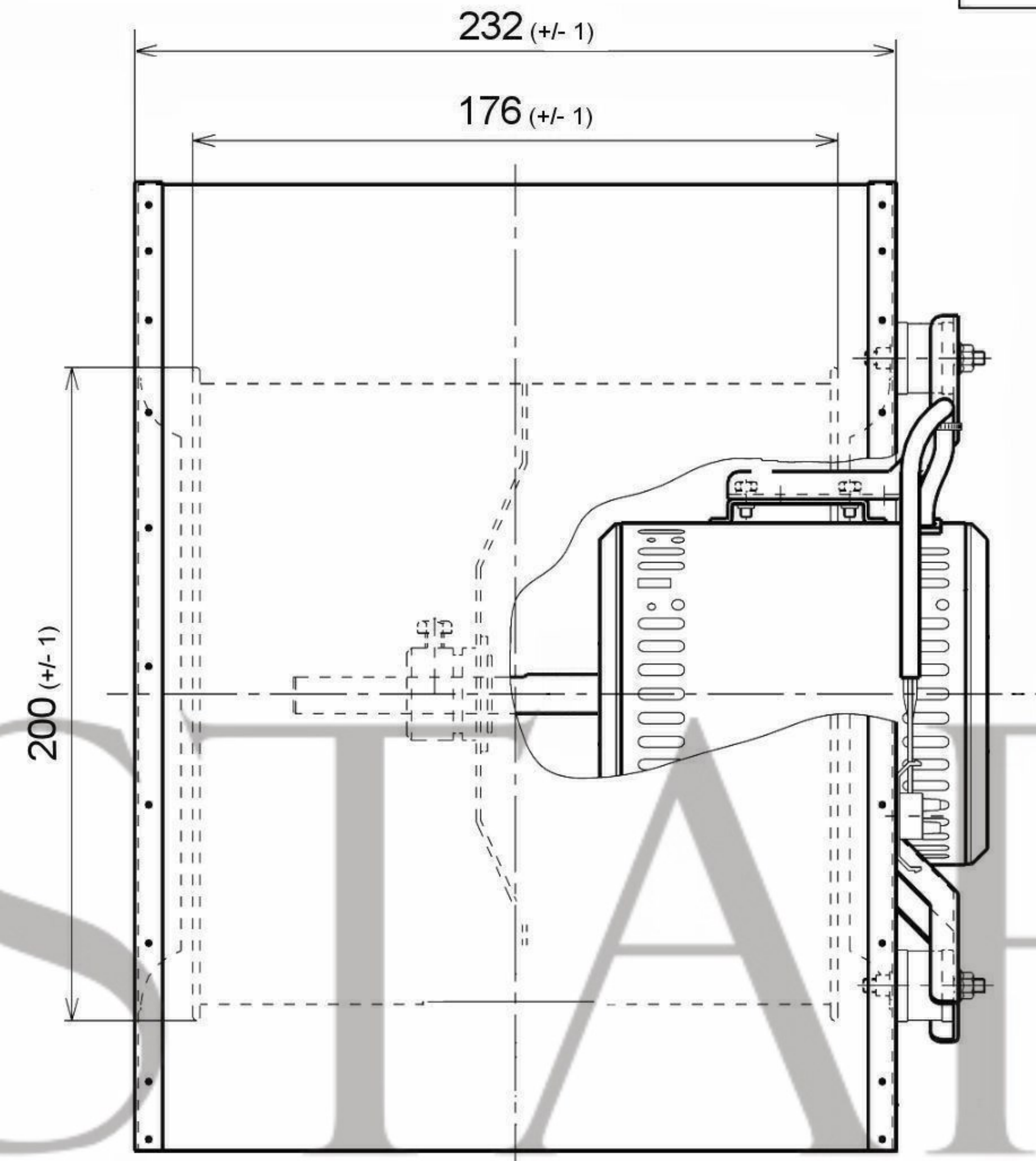

Accessories - DDF7/7 (Flange)

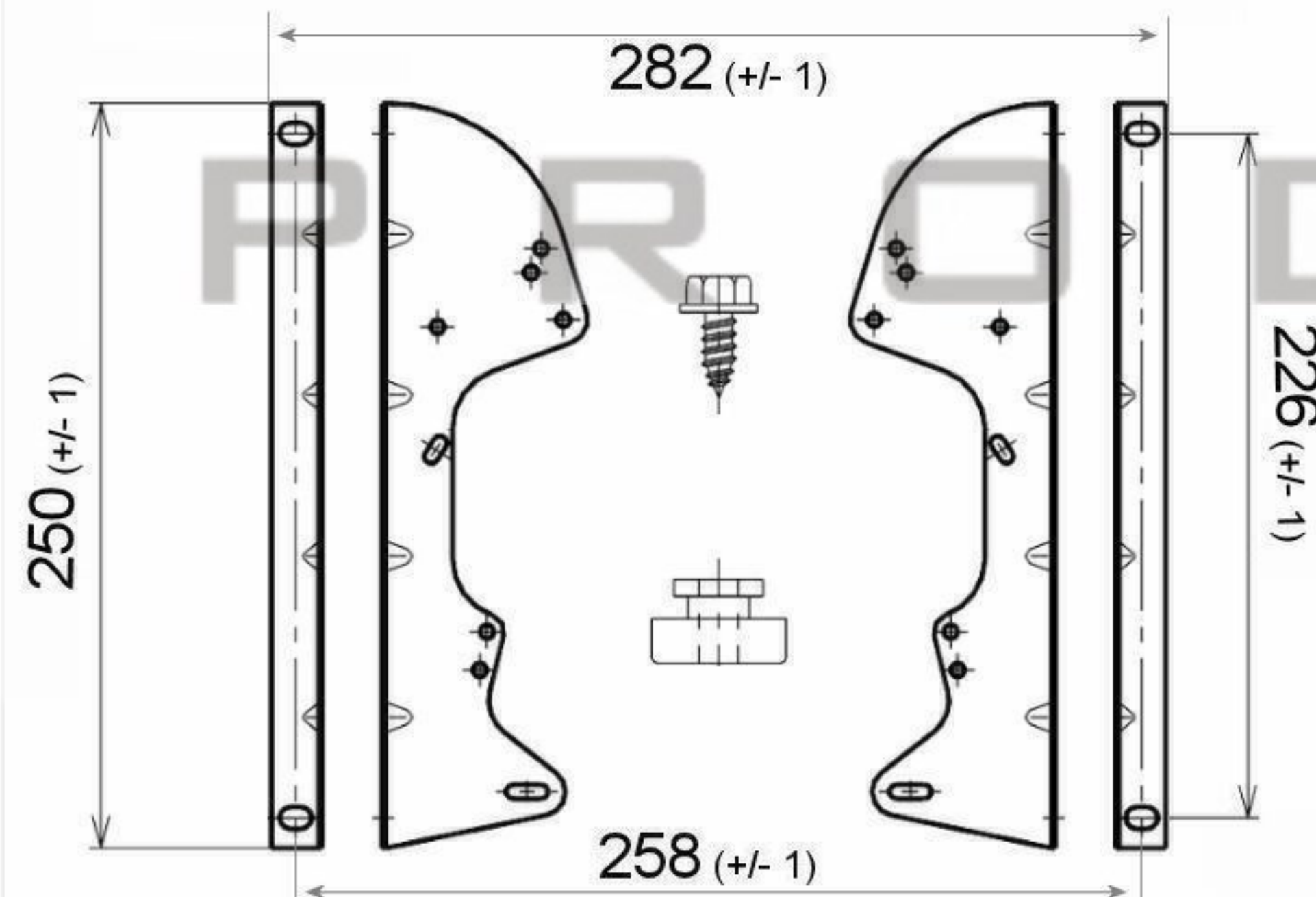
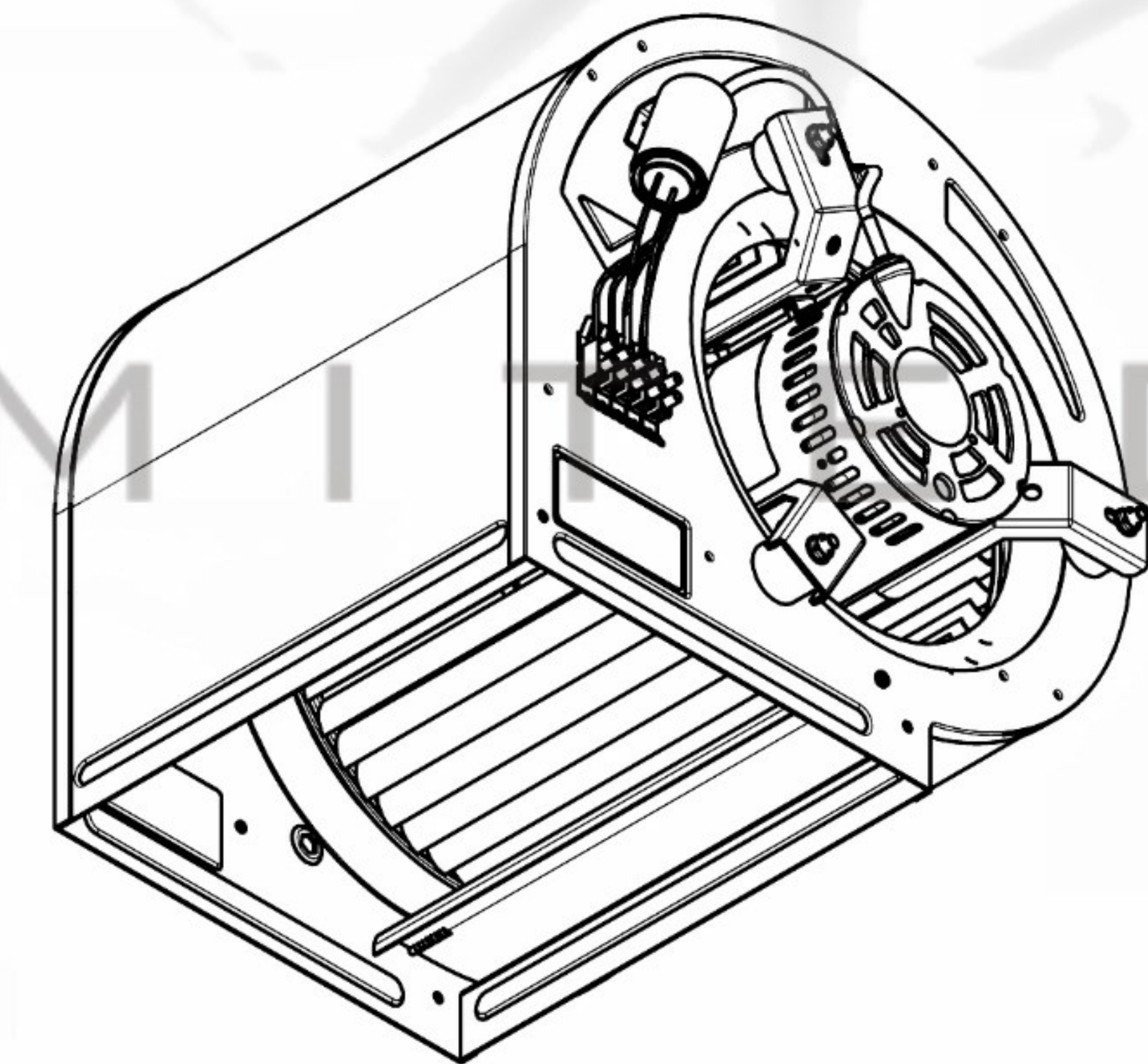
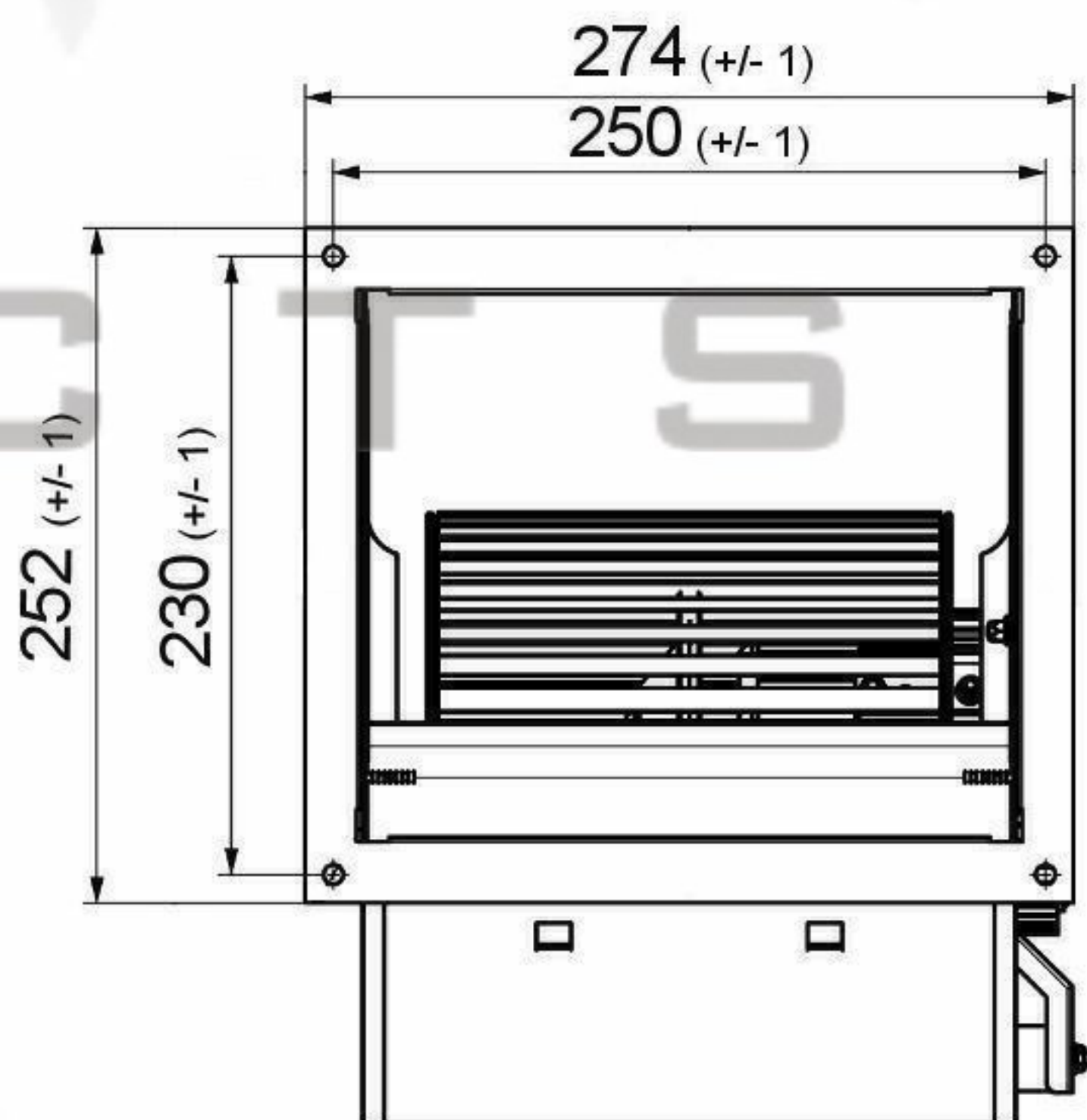

SPECIFICATION					
Motor	PSC	Speed (RPM)	1250	Bearings	Ball
Voltage (V)	230/240	Motor Protection	Th.Prot	Weight (Kg)	9.5
Frequency (Hz)	50/60	Insulation Class	B	Air Volume (M ³ /h)	1490
Power In/Out (W)	100	Protection Class	IP42	Noise Level (dBA)	
Current (A)	1.0	Capacitor (Mf)	5.0	Pressure (Pa)	24.51

POLE STAR
PRODUCTS LIMITED

POLE STAR PRODUCTS LIMITED	
Product Code	DD7/7-F100/1V-1
Projection Angle	± 3°
Scale:	A4
Sheet:	1 of 1

