

Accessories - DD7F (Mounting Feet)

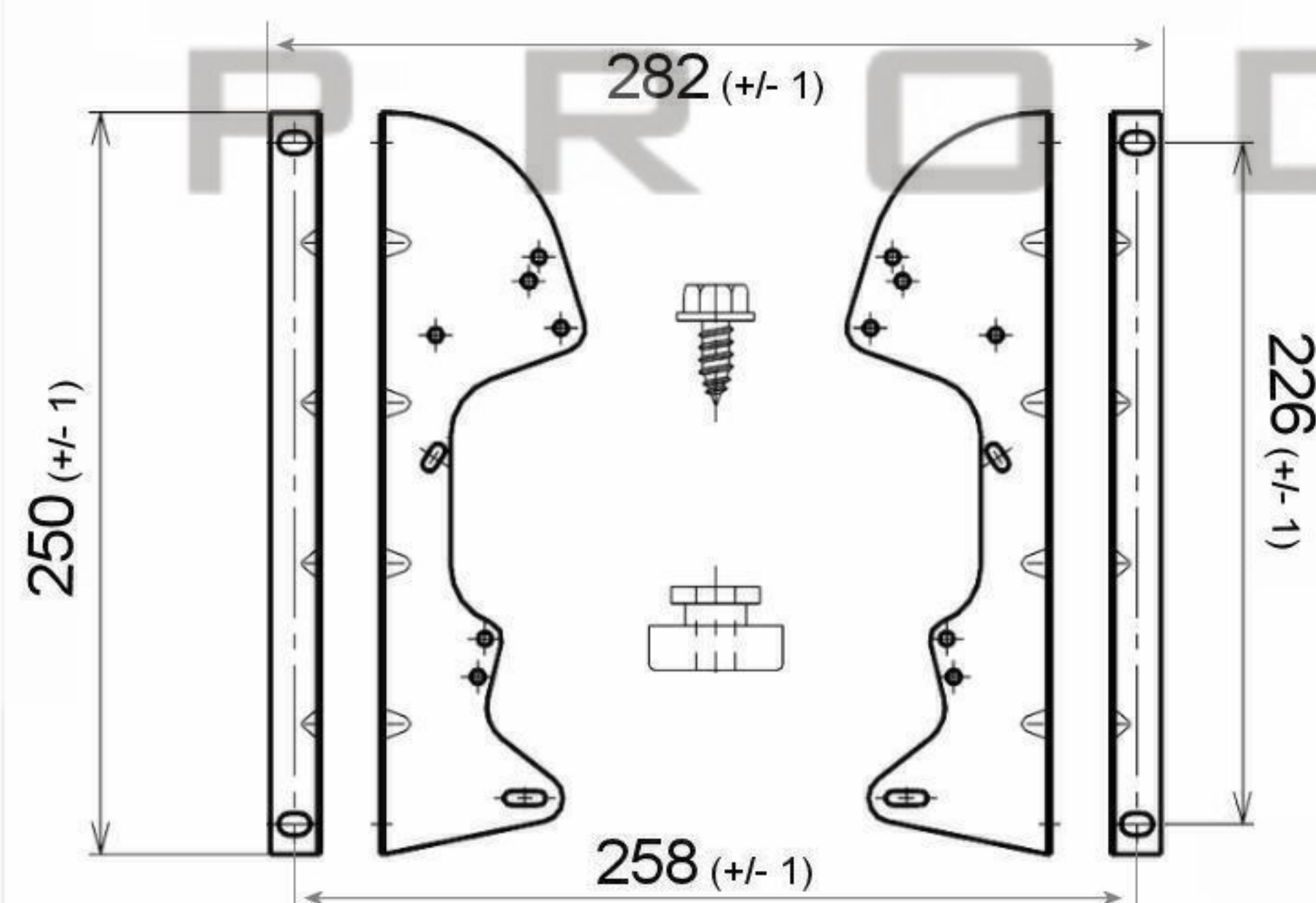

Accessories - DDF7/7 (Flange)

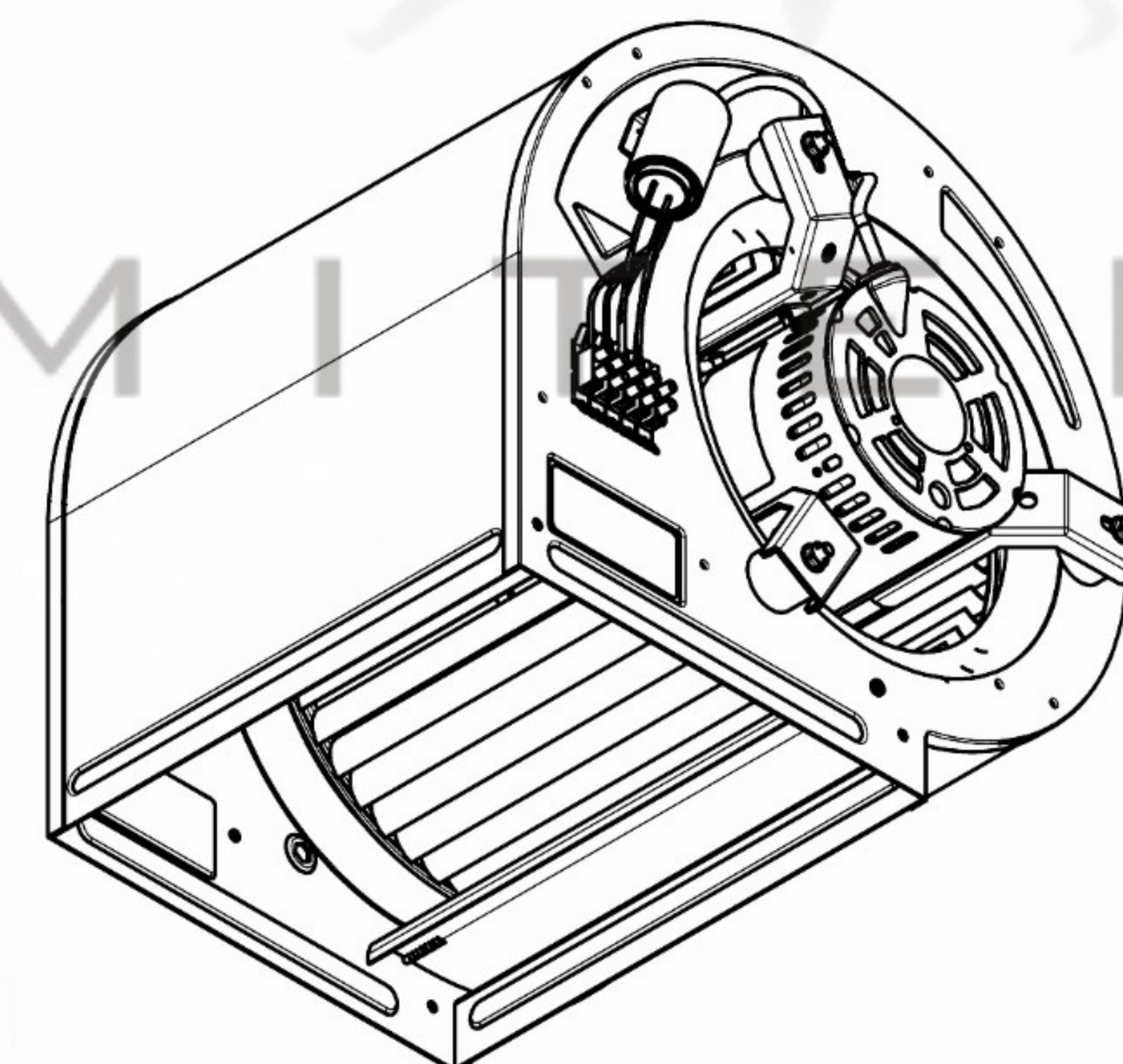
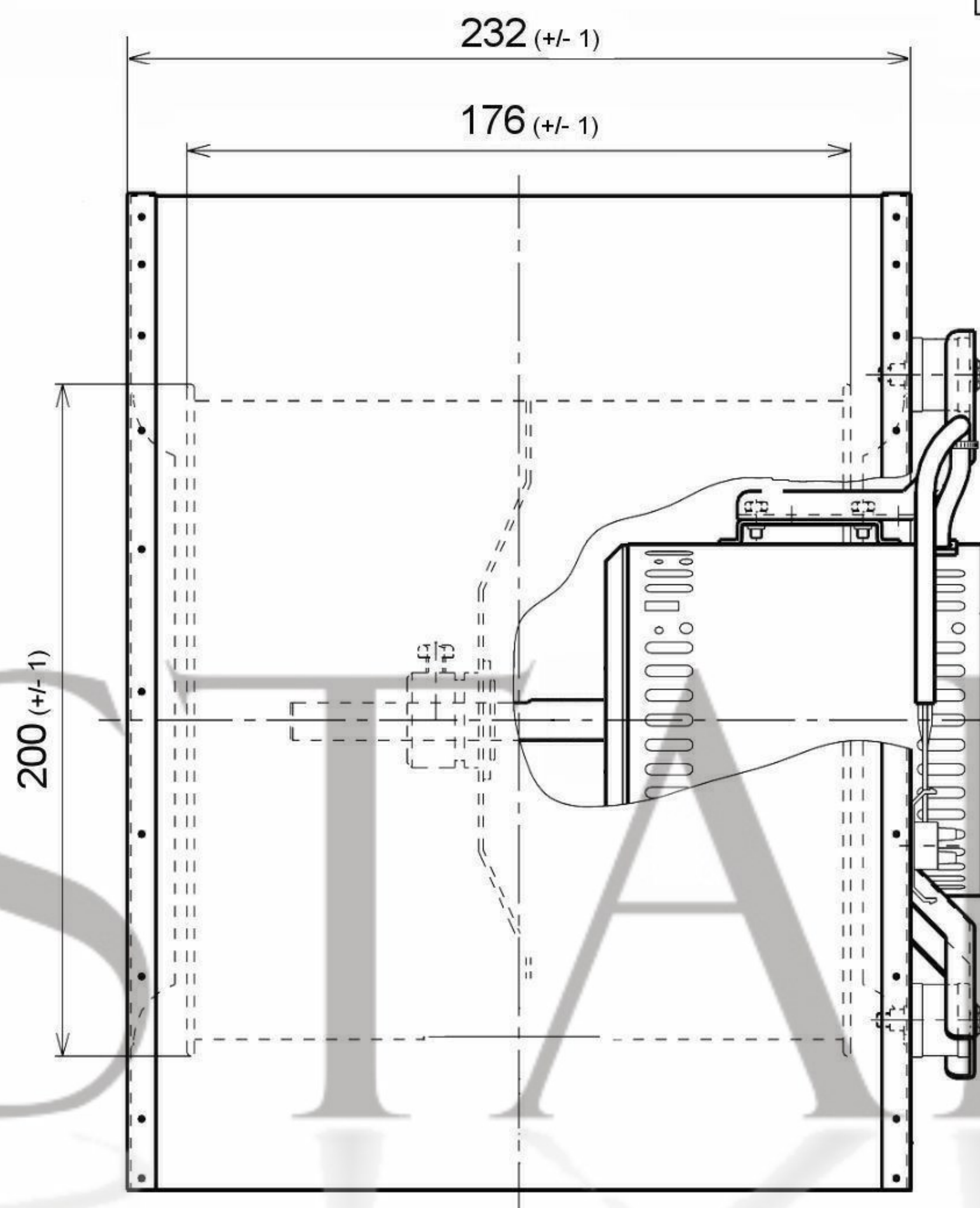
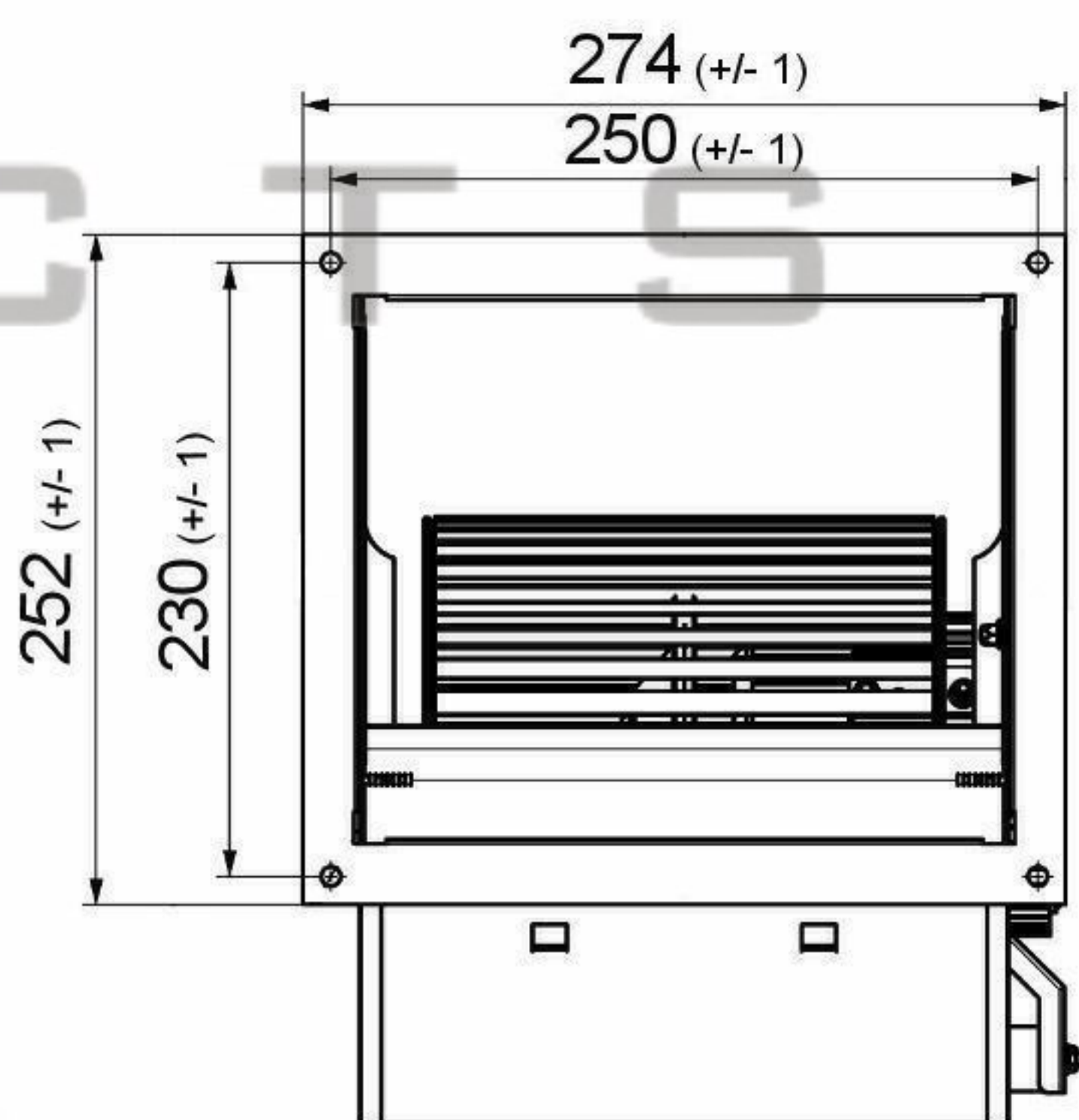

SPECIFICATION					
Motor	PSC	Speed (RPM)	1250	Bearings	Ball
Voltage (V)	230/240	Motor Protection	Th.Prot	Weight (Kg)	10.0
Frequency (Hz)	50/60	Insulation Class	B	Air Volume (M ³ /h)	1500
Power In/Out (W)	150	Protection Class	IP42	Noise Level (dBA)	
Current (A)	1.1	Capacitor (Mf)	5.0	Pressure (Pa)	24.51

POLE STAR
PRODUCTS LIMITED

POLE STAR PRODUCTS LIMITED	
Product Code	
DD7/7-F150/1V-1	
Projection Angle	A4
± 3°	Scale:
	Sheet: 1 of

