

Accessories - DD9F (Mounting Feet)

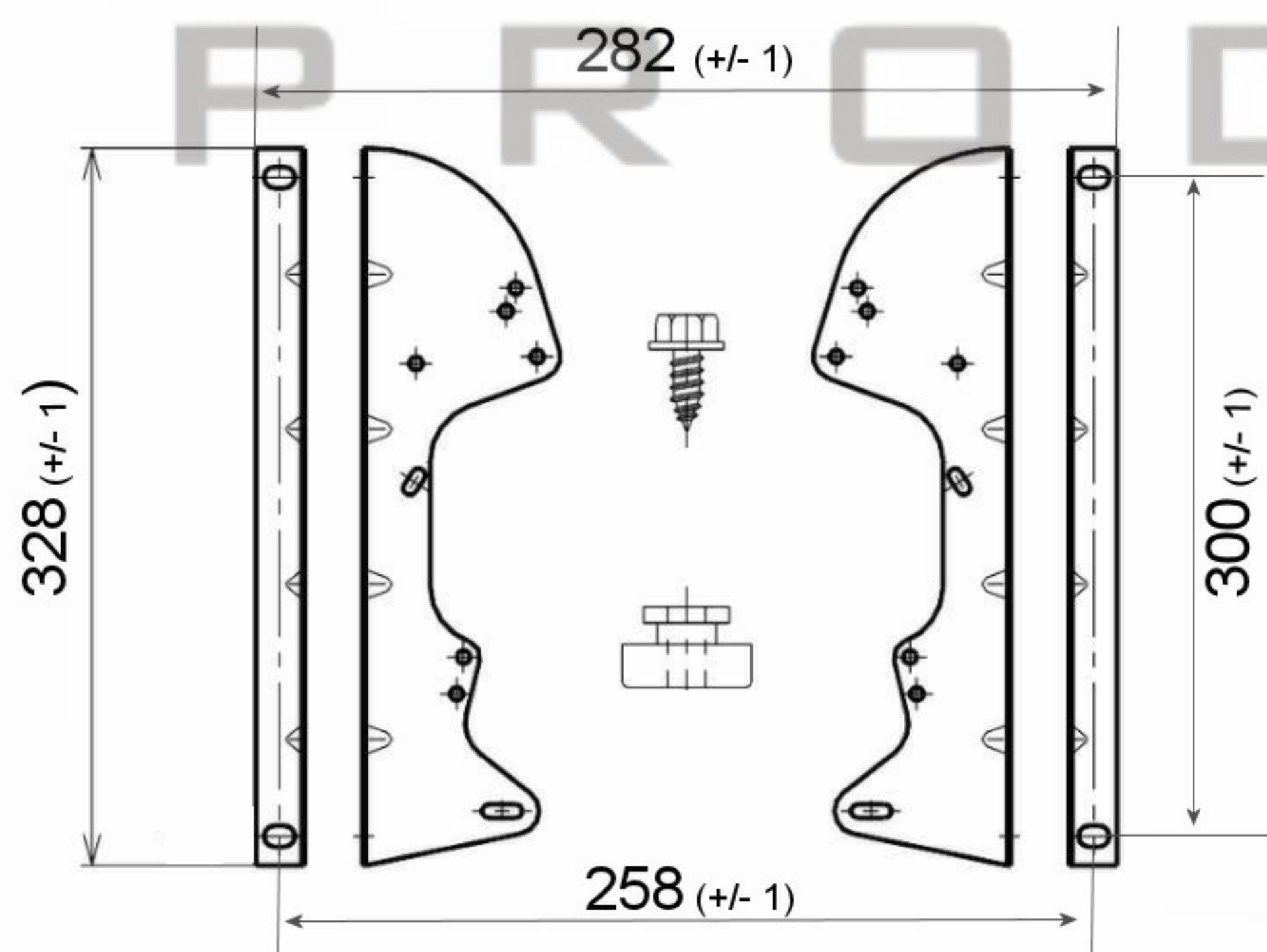

Accessories - DD9/7 (Flange)

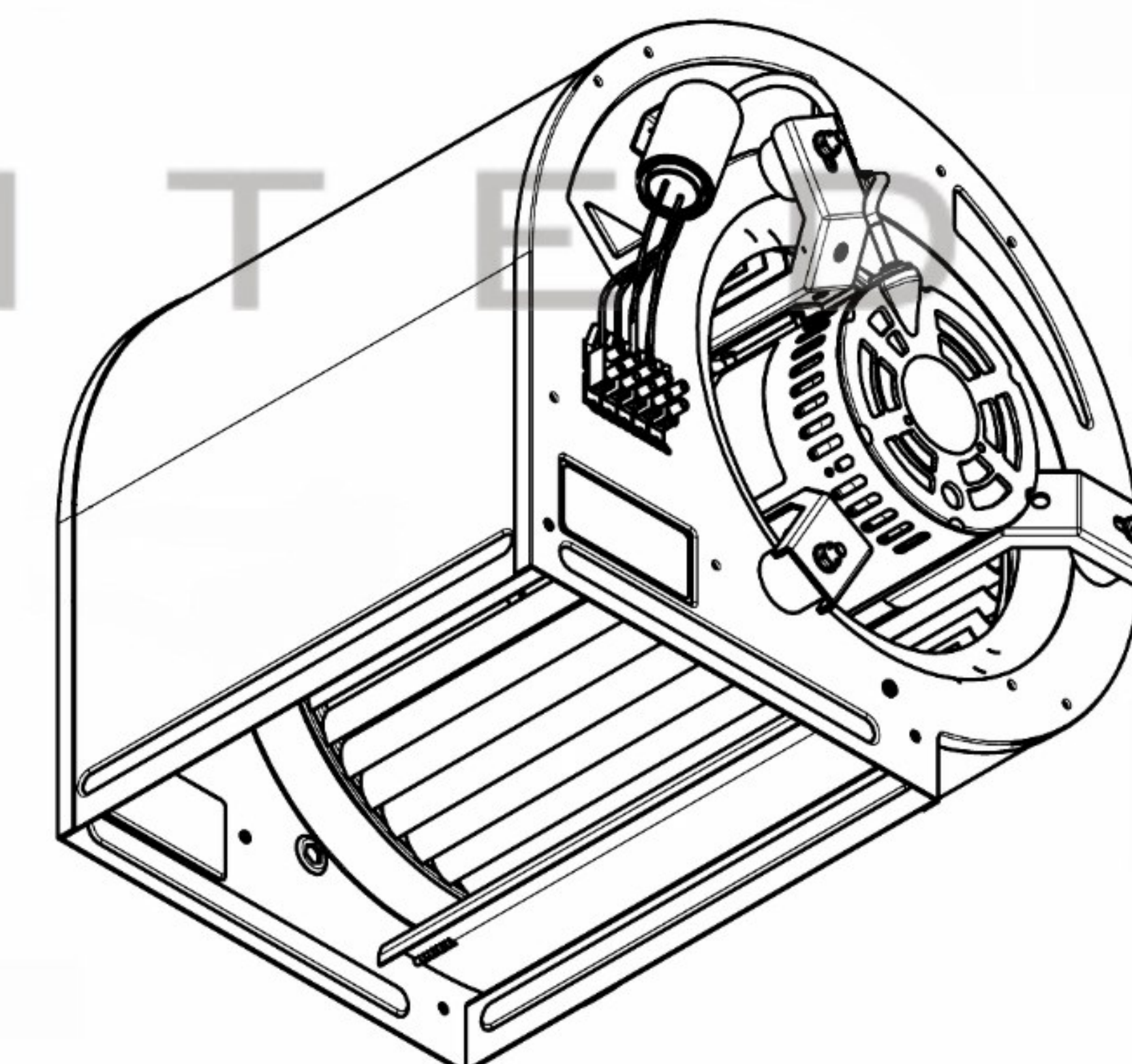
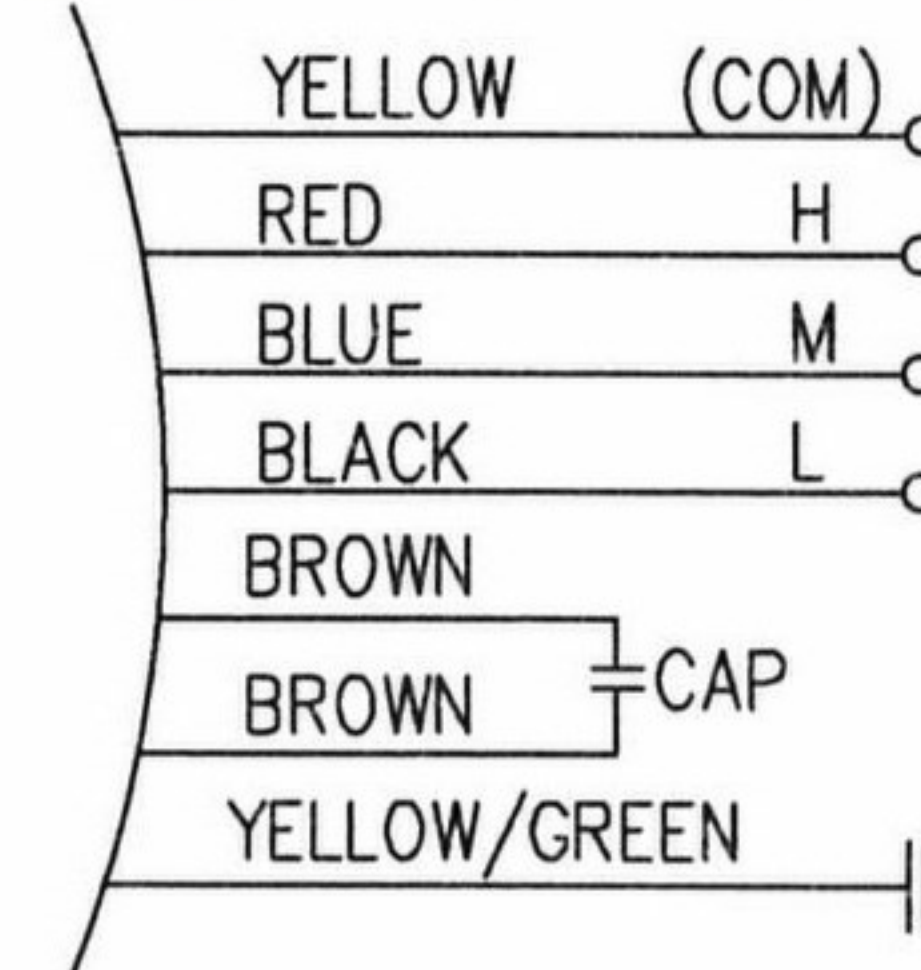
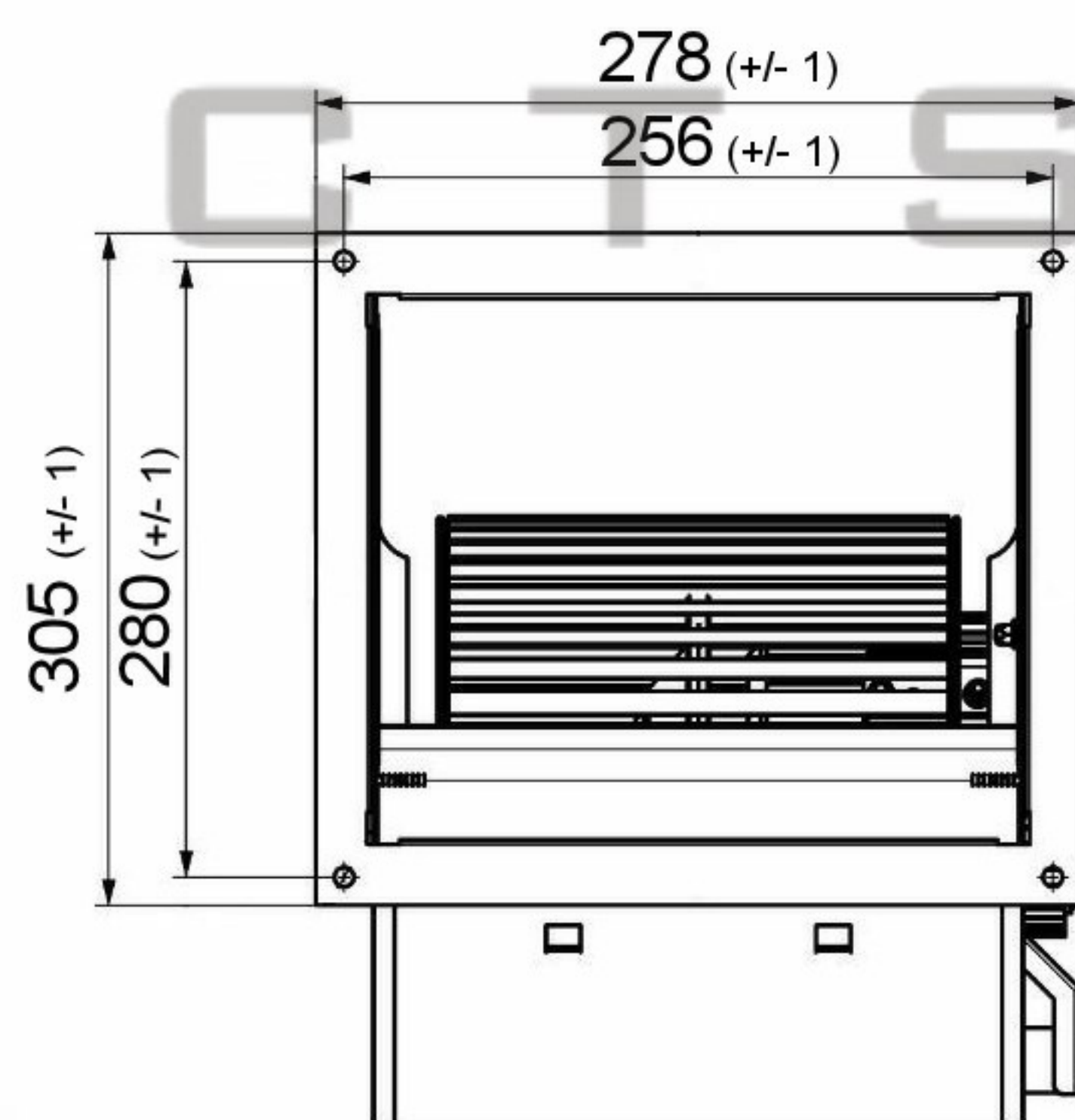

SPECIFICATION					
Motor	PSC	Speed (RPM)	850	Bearings	Ball
Voltage (V)	230/240	Motor Protection	Th.Prot	Weight (Kg)	14.0
Frequency (Hz)	50/60	Insulation Class	B	Air Volume (M ³ /h)	1500/1950 2400
Power In/Out (W)	245	Protection Class	IP42	Noise Level (dBA)	
Current (A)	1.8	Capacitor (Mf)	10	Pressure (Pa)	0.00

POLE STAR
PRODUCTS LIMITED

POLE STAR PRODUCTS LIMITED	
Product Code	
DD9/7-S245/3V-1	
Projection Angle	A4
± 3°	Scale:
	Sheet: 1 of