

Accessories - DDF9/9(Flange)

Accessories - DD9F (Mounting Feet)

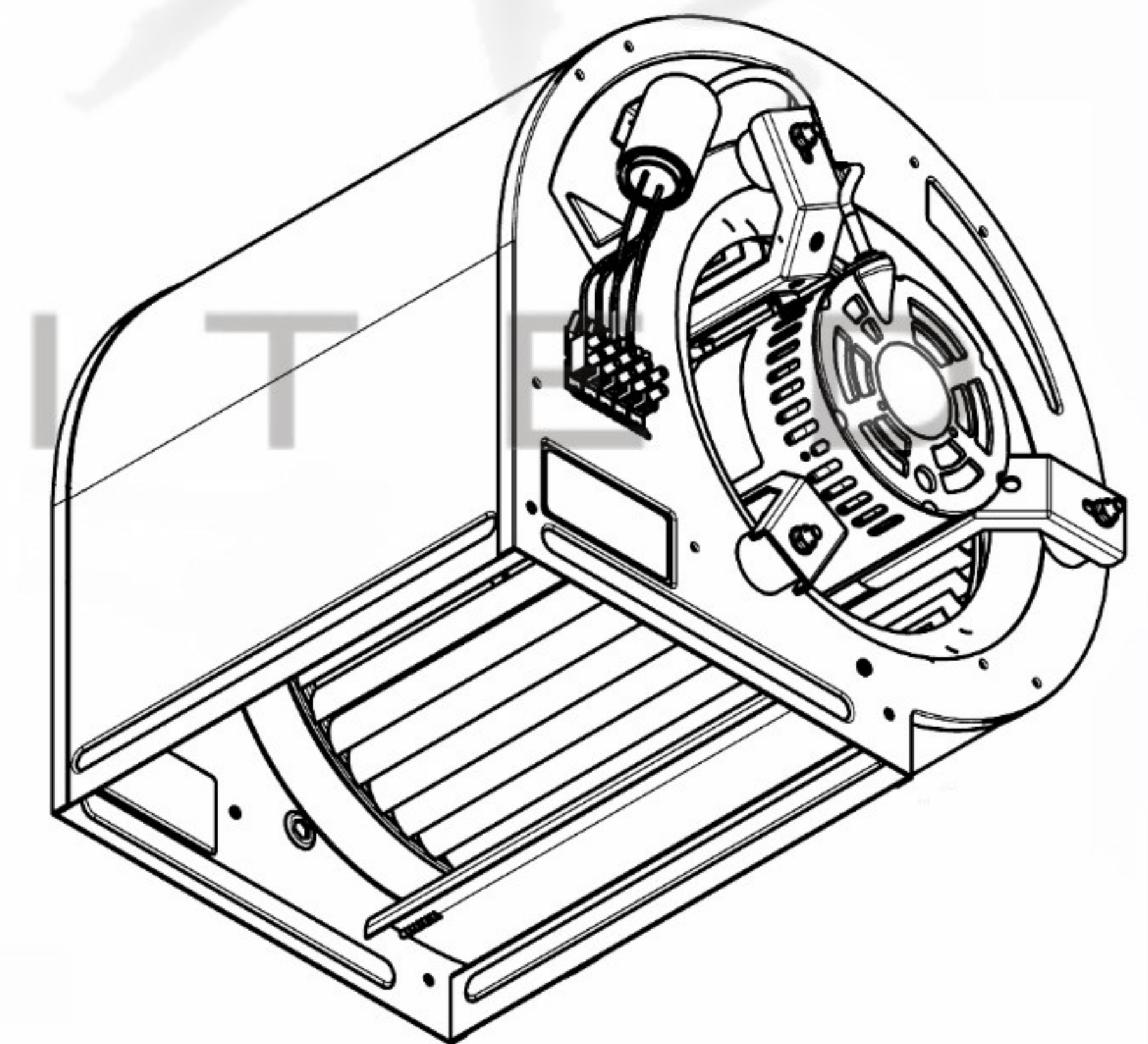
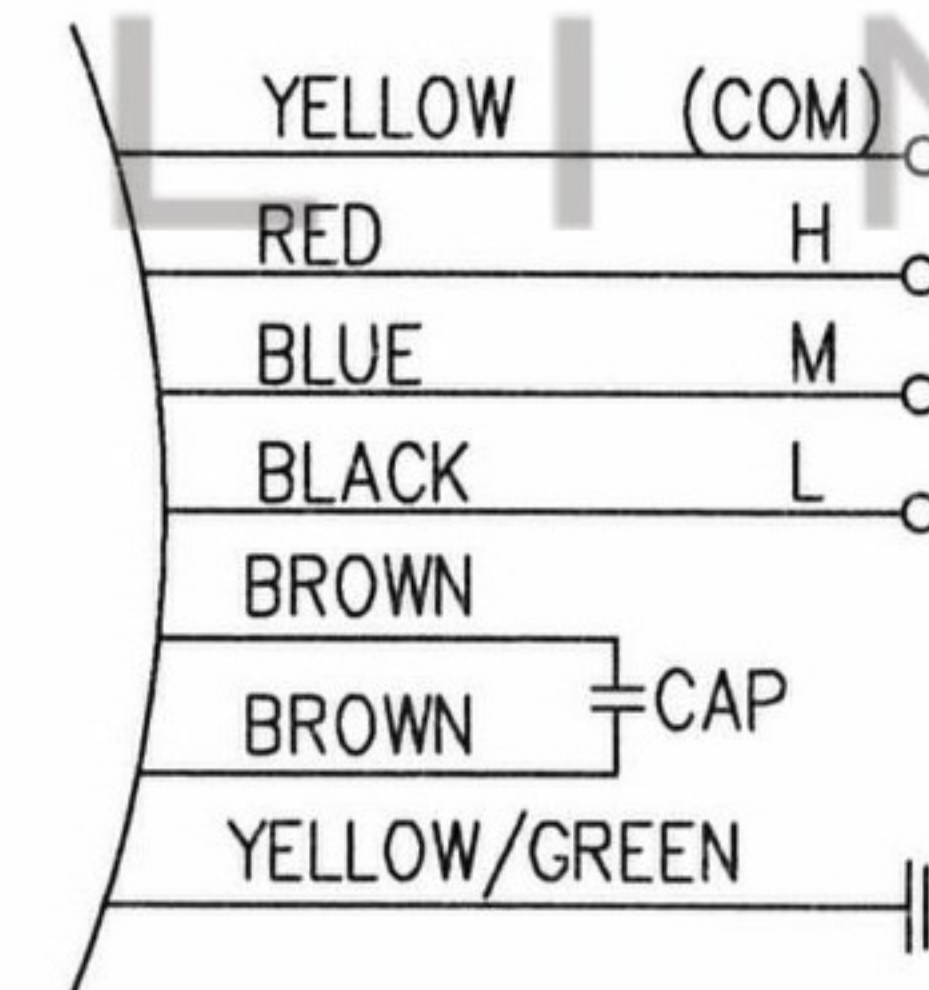
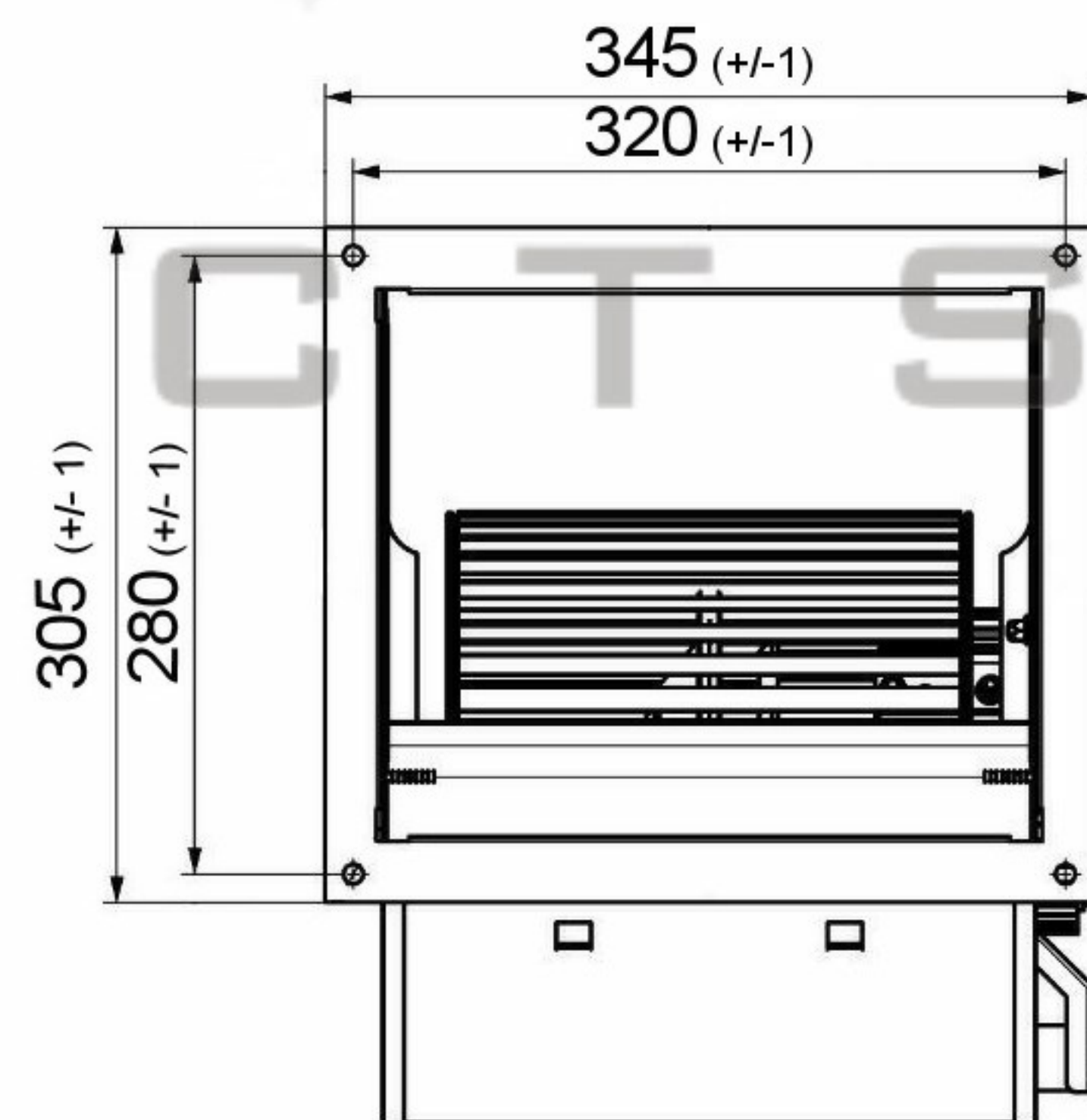
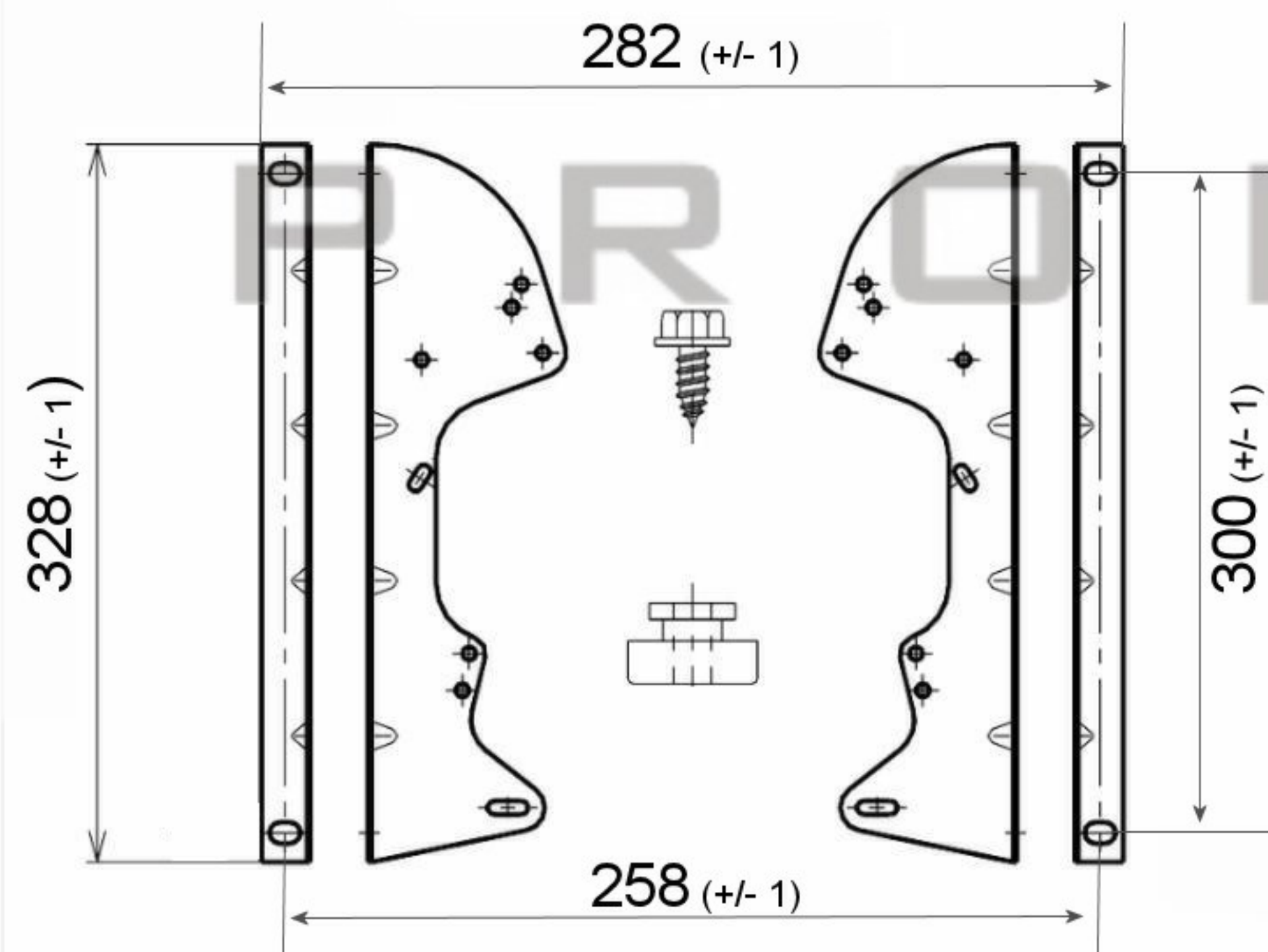

SPECIFICATION					
Motor	PSC	Speed (RPM)	1250	Bearings	Ball
Voltage (V)	230/240	Motor Protection	Th.Prot	Weight (Kg)	14.0
Frequency (Hz)	50/60	Insulation Class	B	Air Volume (M ³ /h)	1750/2950 3000
Power In/Out (W)	600/370	Protection Class	IP42	Noise Level (dBA)	
Current (A)	3.0	Capacitor (Mf)	12.5	Pressure (Pa)	0.00

POLE STAR
PRODUCTS LIMITED

POLE STAR PRODUCTS LIMITED	
Product Code DD9/9-F370/3V-1	
Projection Angle ± 3°	A4 Scale: Sheet: 1 of