

**Accessories - DDF9/9(Flange)**

**Accessories - DD9F (Mounting Feet)**

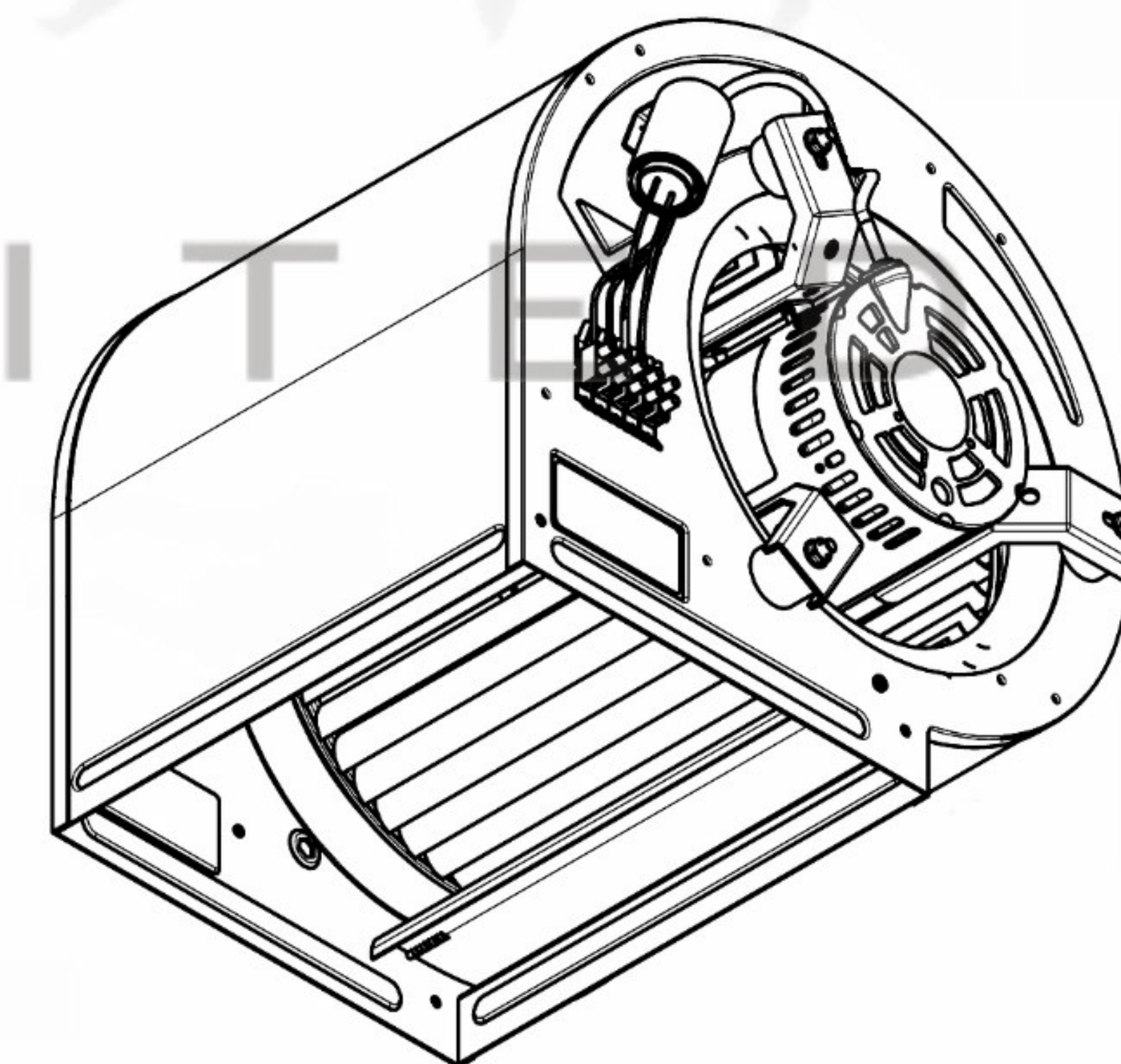
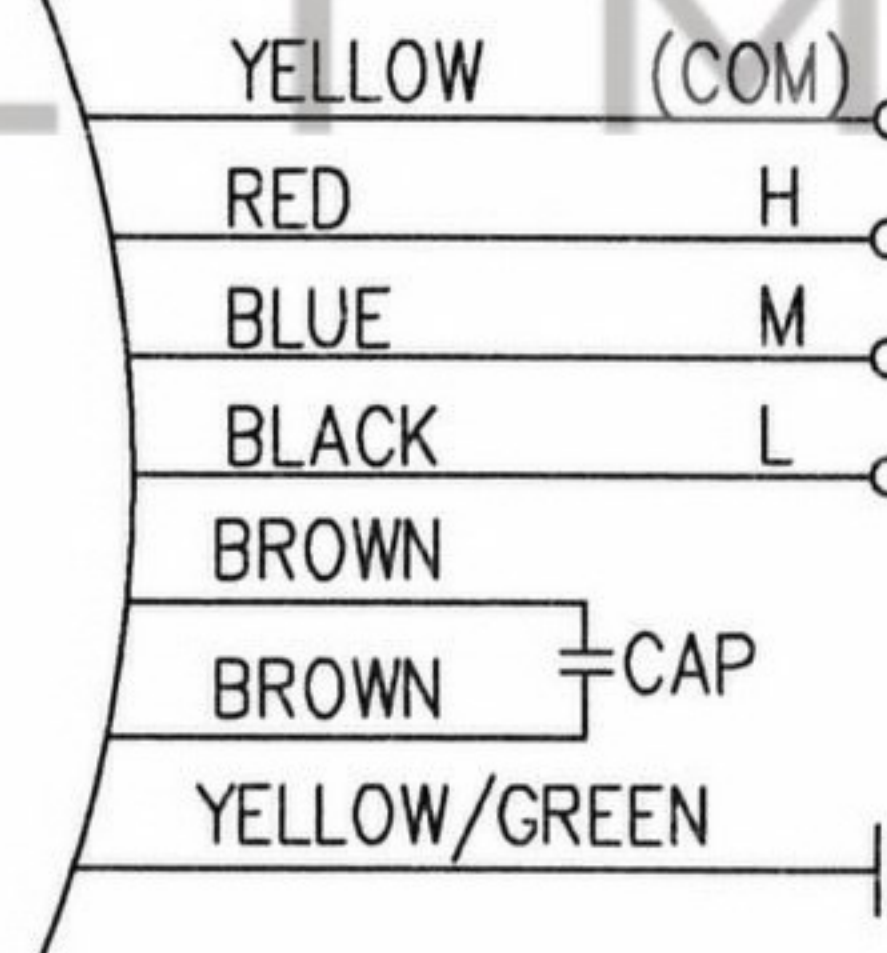
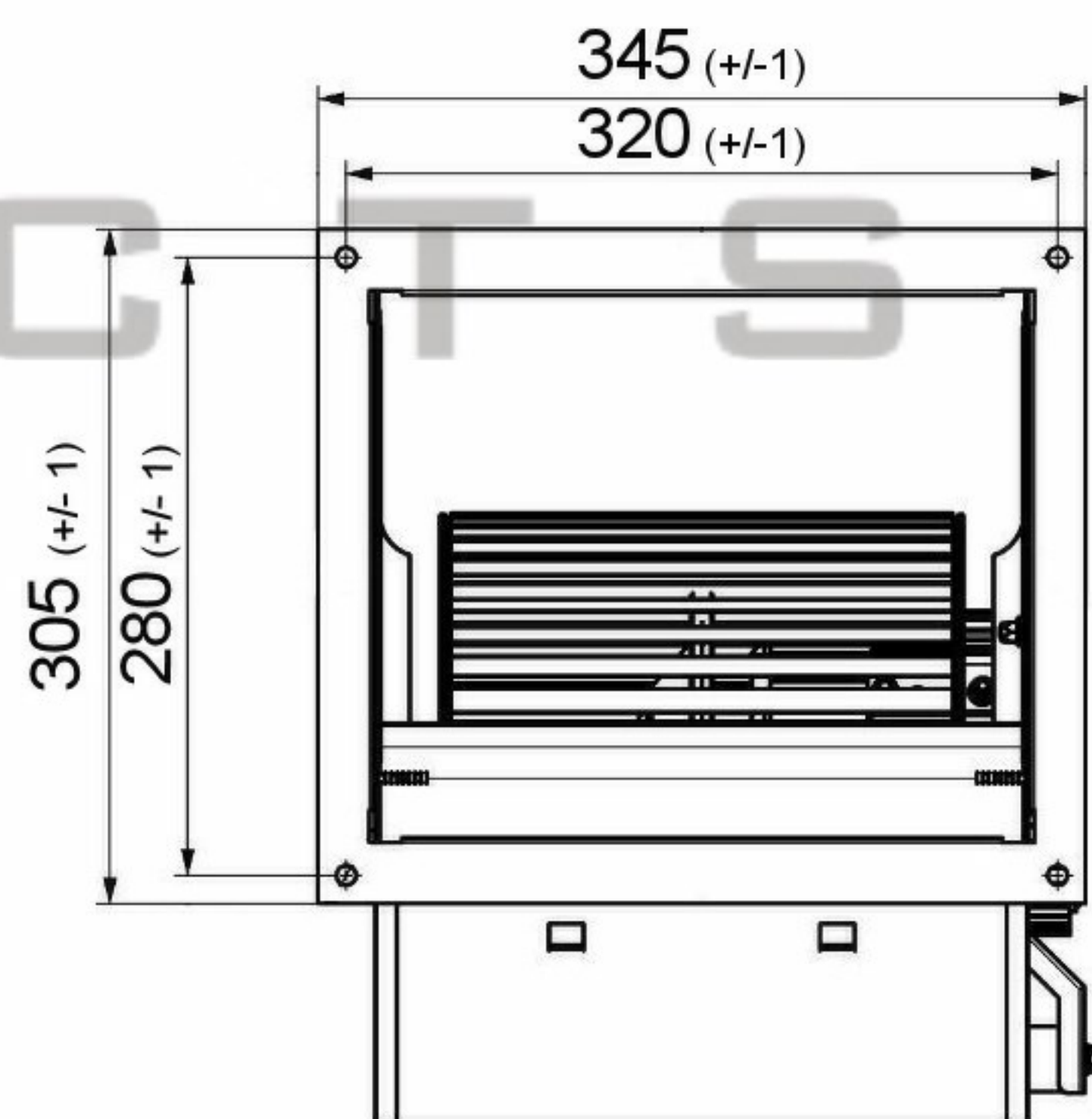
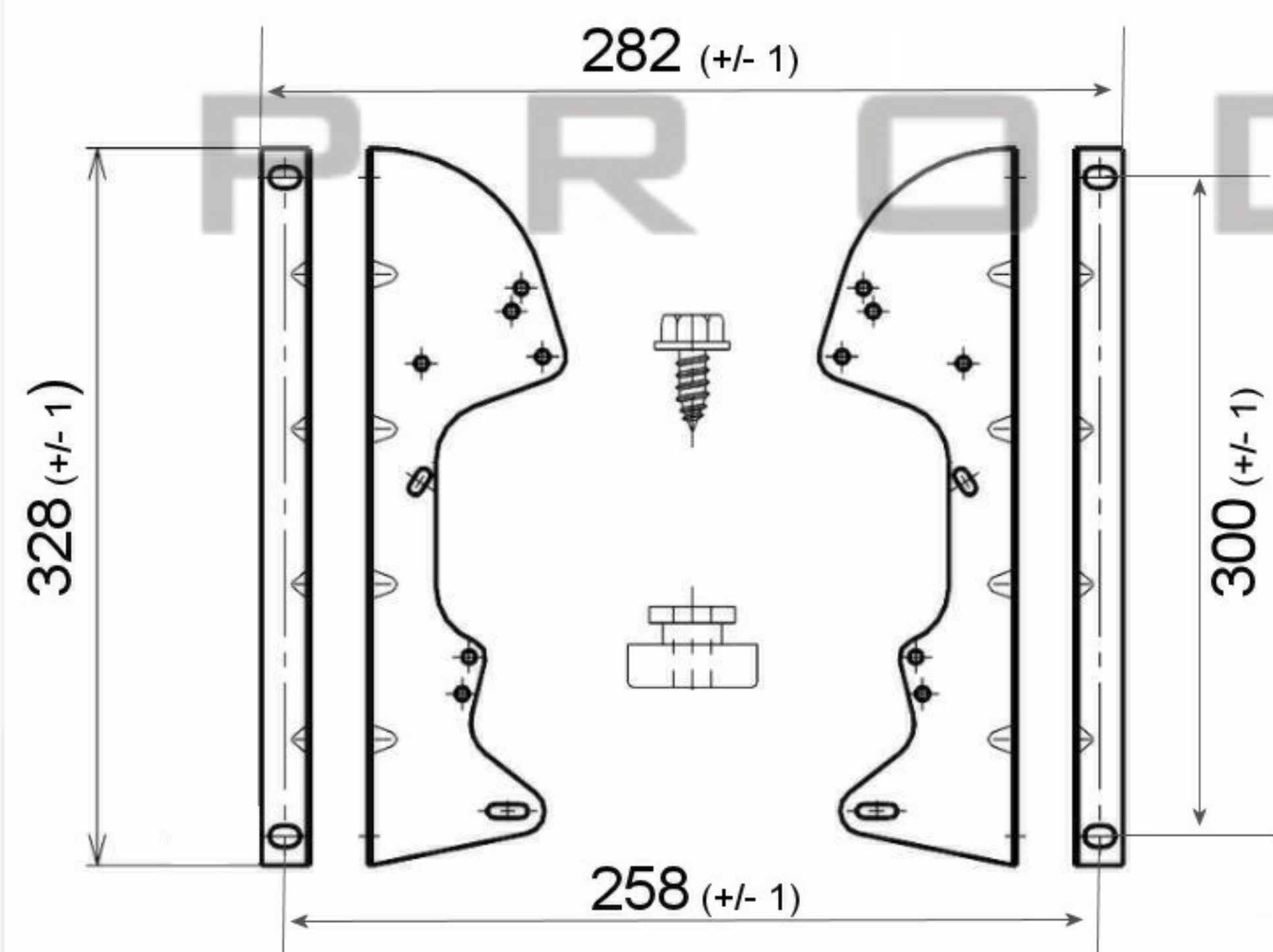

SPECIFICATION					
Motor	PSC	Speed (RPM)	1250	Bearings	Ball
Voltage (V)	230/240	Motor Protection	Th.Prot	Weight (Kg)	17.0
Frequency (Hz)	50/60	Insulation Class	B	Air Volume (M <sup>3</sup> /h)	3900
Power In/Out (W)	550	Protection Class	IP42	Noise Level (dBA)	
Current (A)	3.8	Capacitor (Mf)	15.0	Pressure (Pa)	78.45

**POLE STAR**  
PRODUCTS LIMITED

POLE STAR PRODUCTS LIMITED	
Product Code	<b>DD9/9-F550/3V-1</b>
Projection Angle ± 3°	
	A4
	Scale: Sheet: 1 of