

Accessories - DDF9/9(Flange)

Accessories - DD9F (Mounting Feet)

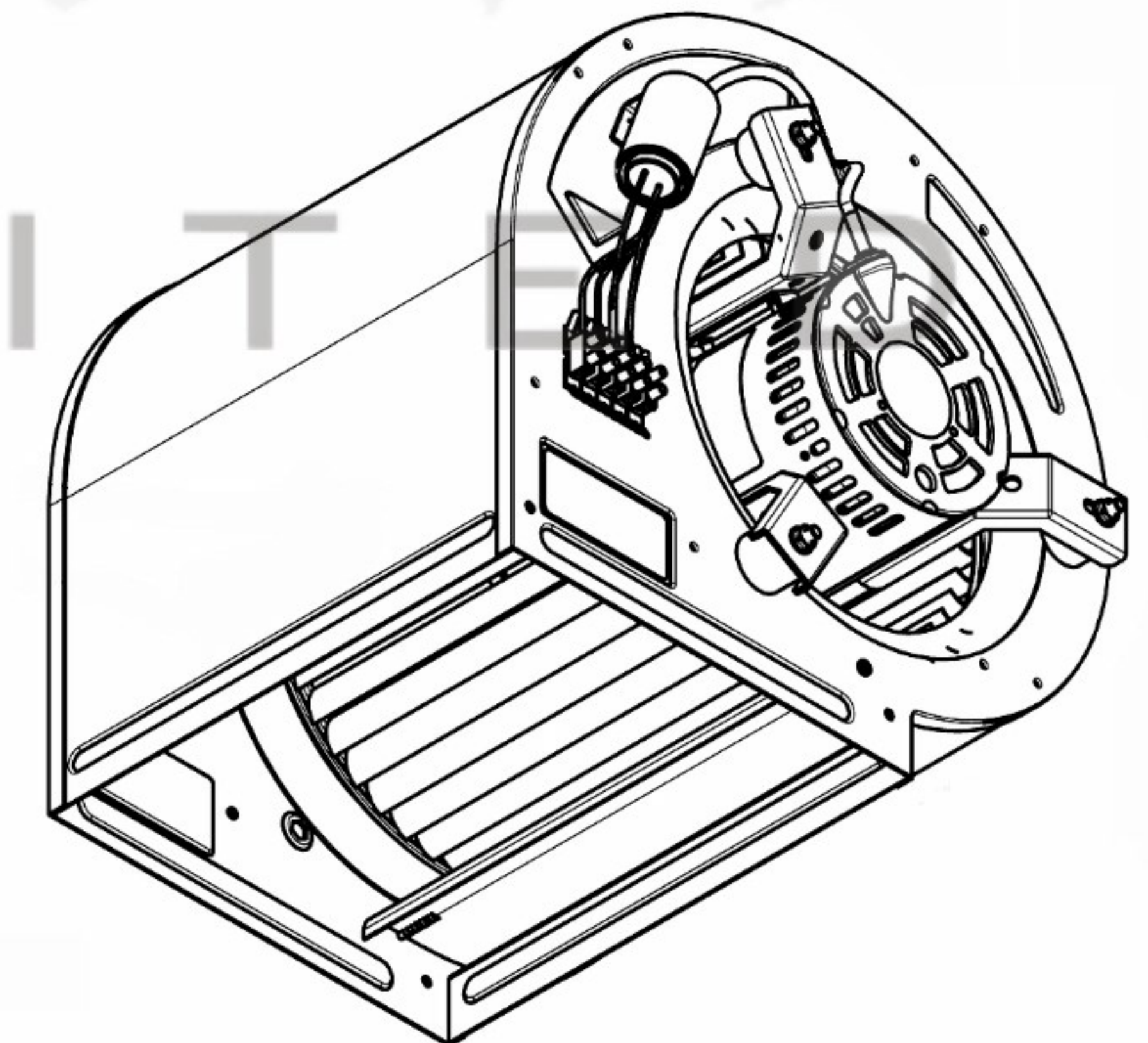
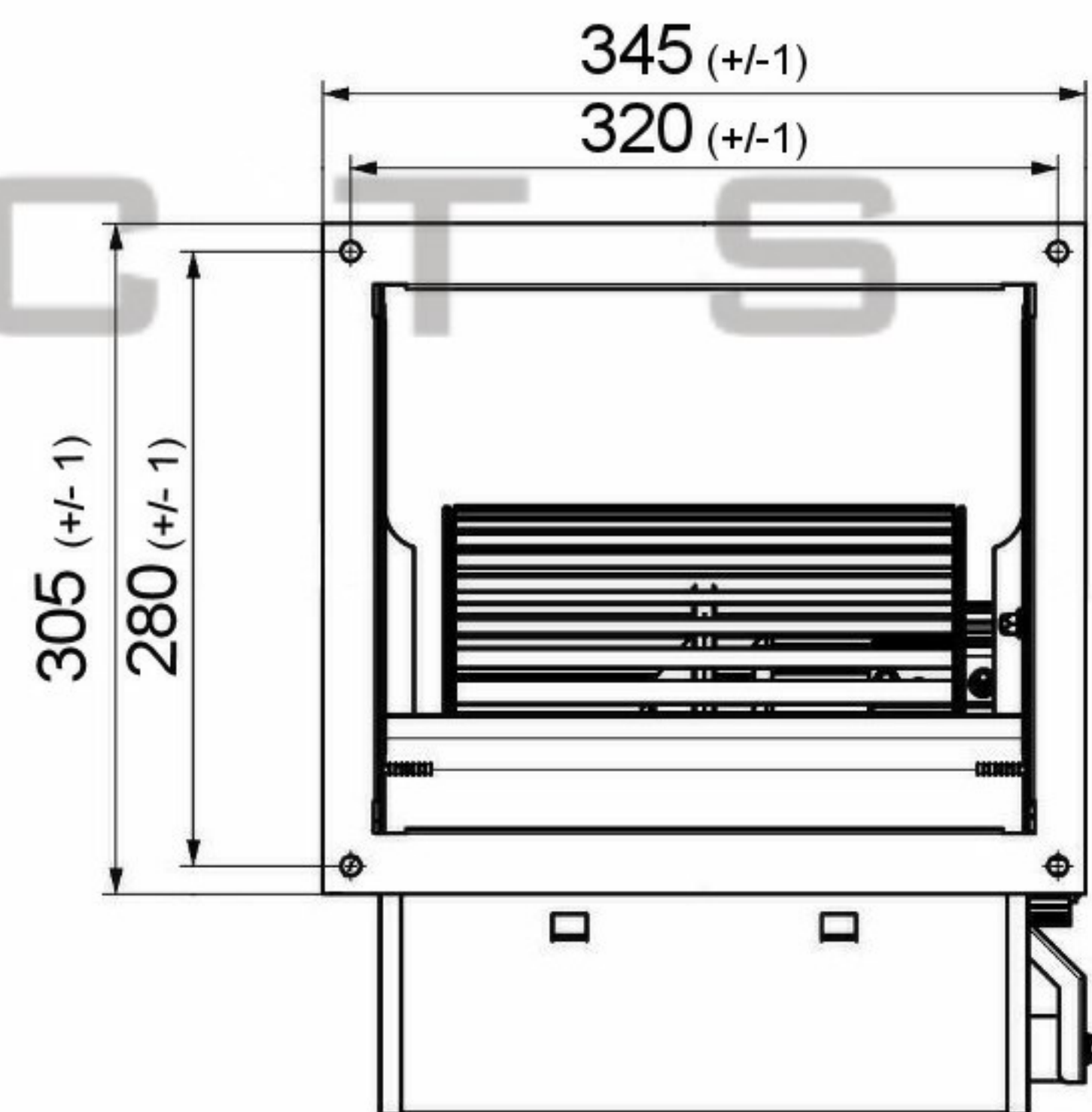
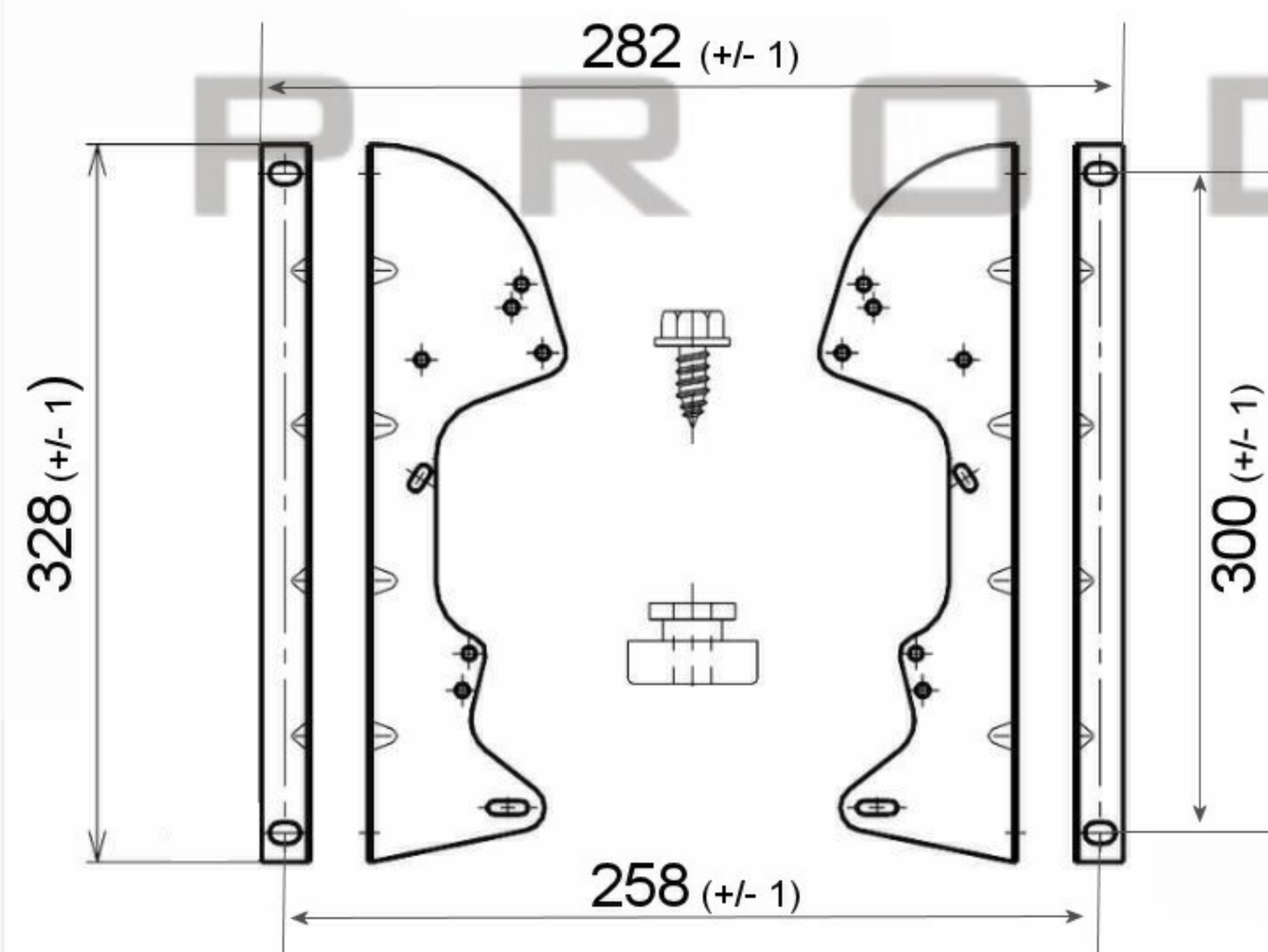

| SPECIFICATION | | | | | |
|------------------|---------|------------------|---------|-------------------|------|
| Motor | PSC | Speed (RPM) | 850 | Bearings | Ball |
| Voltage (V) | 230/240 | Motor Protection | Th.Prot | Weight (Kg) | 17.0 |
| Frequency (Hz) | 50/60 | Insulation Class | B | Air Volume (M³/h) | 3150 |
| Power In/Out (W) | 335 | Protection Class | IP42 | Noise Level (dBA) | |
| Current (A) | 2.6 | Capacitor (Mf) | 8.0 | Pressure (Pa) | 0.00 |

POLE STAR
PRODUCTS LIMITED

| | |
|----------------------------|------------------------|
| POLE STAR PRODUCTS LIMITED | |
| Product Code | DD9/9-S335/1V-1 |
| Projection Angle | ± 3° |
| | |
| | A4 |
| | Scale: |
| | Sheet: 1 of |