

LEAD WIRES ASS'Y ①			LEAD WIRES ASS'Y ②		
	COLOR	SPEC		COLOR	SPEC
L	BROWN	AC220V/50Hz	Vcc	RED	DC10V
N	BLUE	AC220V/50Hz	Vsp	YELLOW	0-10V/PWM
PE	YELLOW/GREEN	EARTH	GND	BLACK	GND
			FG	WHITE	1Pulse/R

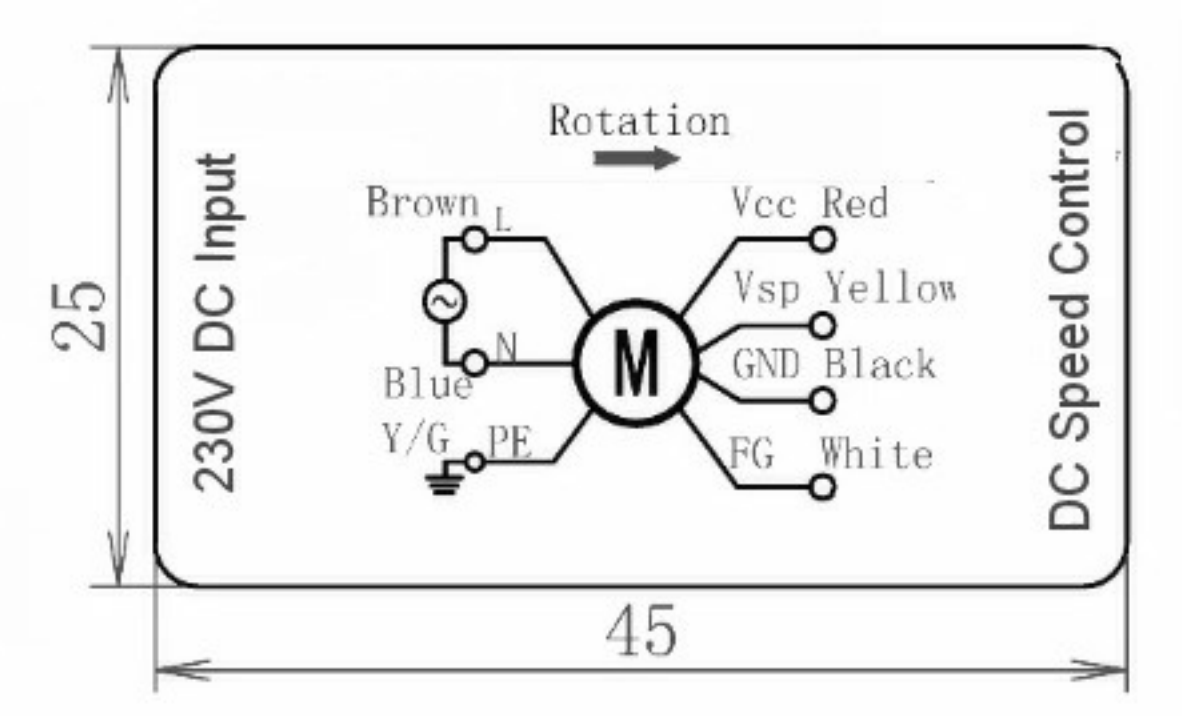

SPECIFICATION					
Motor	EC	Speed (RPM)	2870	Bearings	BALL
Voltage (V)	230V AC	Motor Protection	Th.Prot.	Weight (Kg)	
Frequency (Hz)	50	Insulation Class	B	Noise (dB)	69
Power In/Out (W)	150	Protection Class	IP42	Temp.Range (°C)	-25 / +60
Current (A)	1.113				

POLE STAR
PRODUCTS LIMITED

POLE STAR PRODUCTS LIMITED	
Product Code	GMA1-250S-EC
Projection Angle	$\pm 3^\circ$
Scale:	A4
Sheet:	1 of 1