

All measurements shown are in millimeters

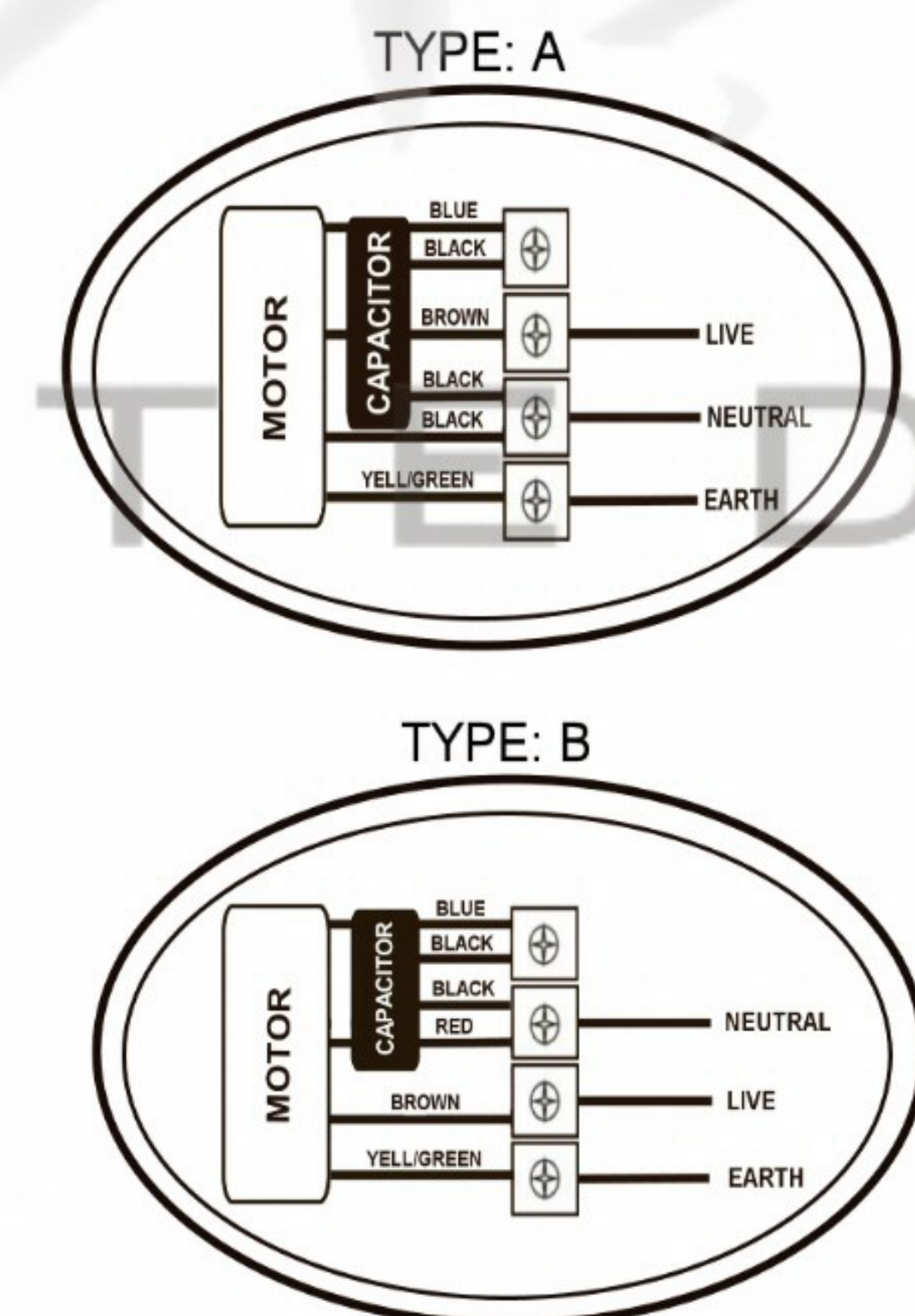

SPECIFICATION					
Motor	PSC	Speed (RPM)	1380	Bearings	Ball
Voltage (V)	220	Motor Protection	Th. Prot	Weight (Kg)	8
Frequency (Hz)	50	Insulation Class	B	Air Volume (M <sup>3</sup> /h)	5600
Power In/Out (W)	240	Protection Class	IP54	Noise Level (dBA)	68
Current (A)	1.08	Temp. Range	-30 +60	Capacitor (MF)	8

**POLE STAR**  
PRODUCTS LIMITED

POLE STAR PRODUCTS LIMITED	
Product Code	
<b>GMA1-450B-1</b>	
Projection Angle	A4
± 3°	Scale:
	Sheet: 1 of