

All measurements shown are in millimeters

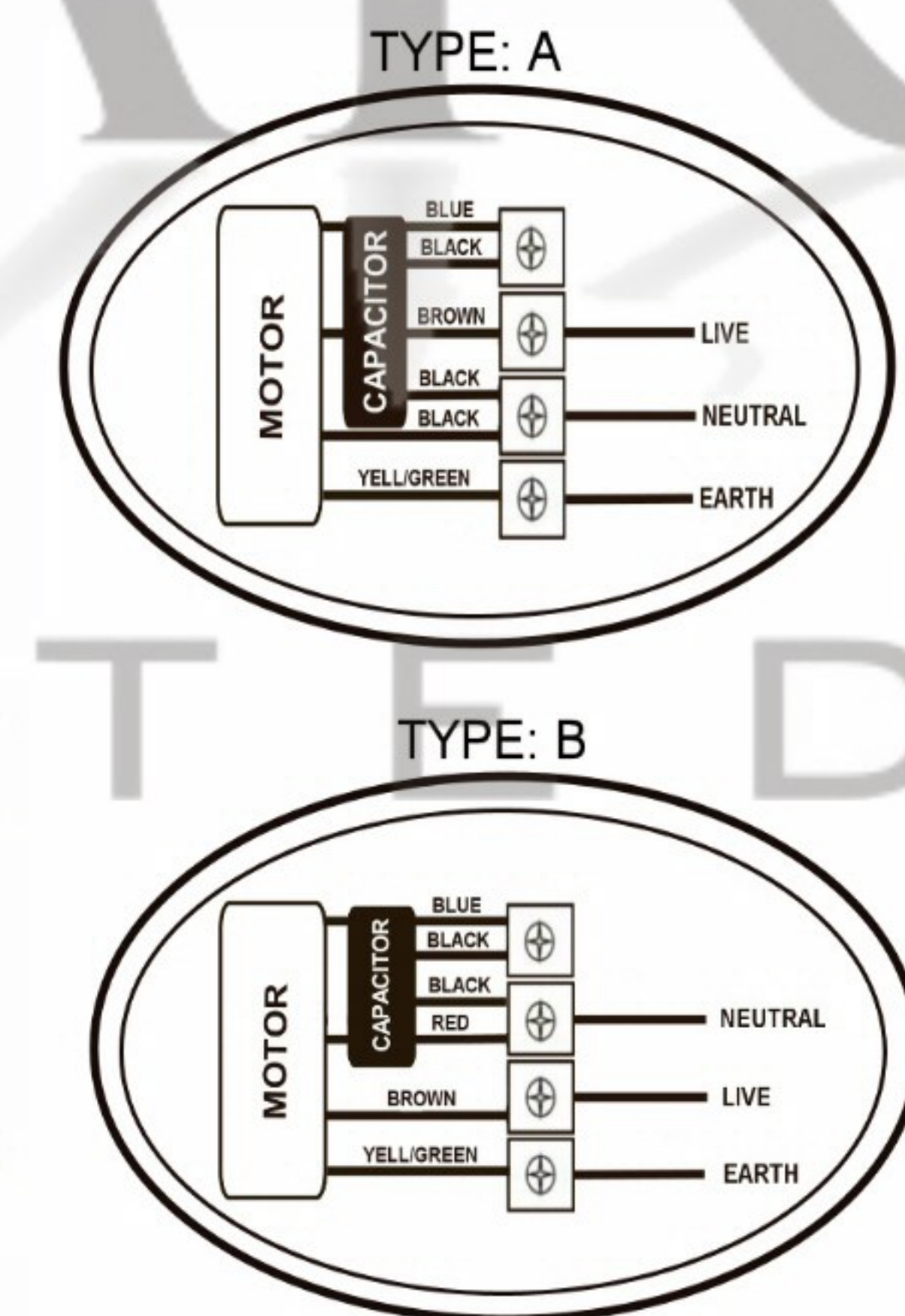

SPECIFICATION					
Motor	PSC	Speed (RPM)	1300	Bearings	Ball
Voltage (V)	220	Motor Protection	Th. Prot	Weight (Kg)	11
Frequency (Hz)	50	Insulation Class	B	Air Volume (M ³ /h)	8010
Power In/Out (W)	550	Protection Class	IP54	Noise Level (dBA)	75
Current (A)	2.55	Temp. Range	-30 +60	Capacitor (MF)	12

POLE STAR
PRODUCTS LIMITED

POLE STAR PRODUCTS LIMITED
 Product Code
GMA1-550BH4-1

Projection Angle ± 3°

A4
 Scale:
 Sheet: 1 of