

Wheel Size: 190 x 45

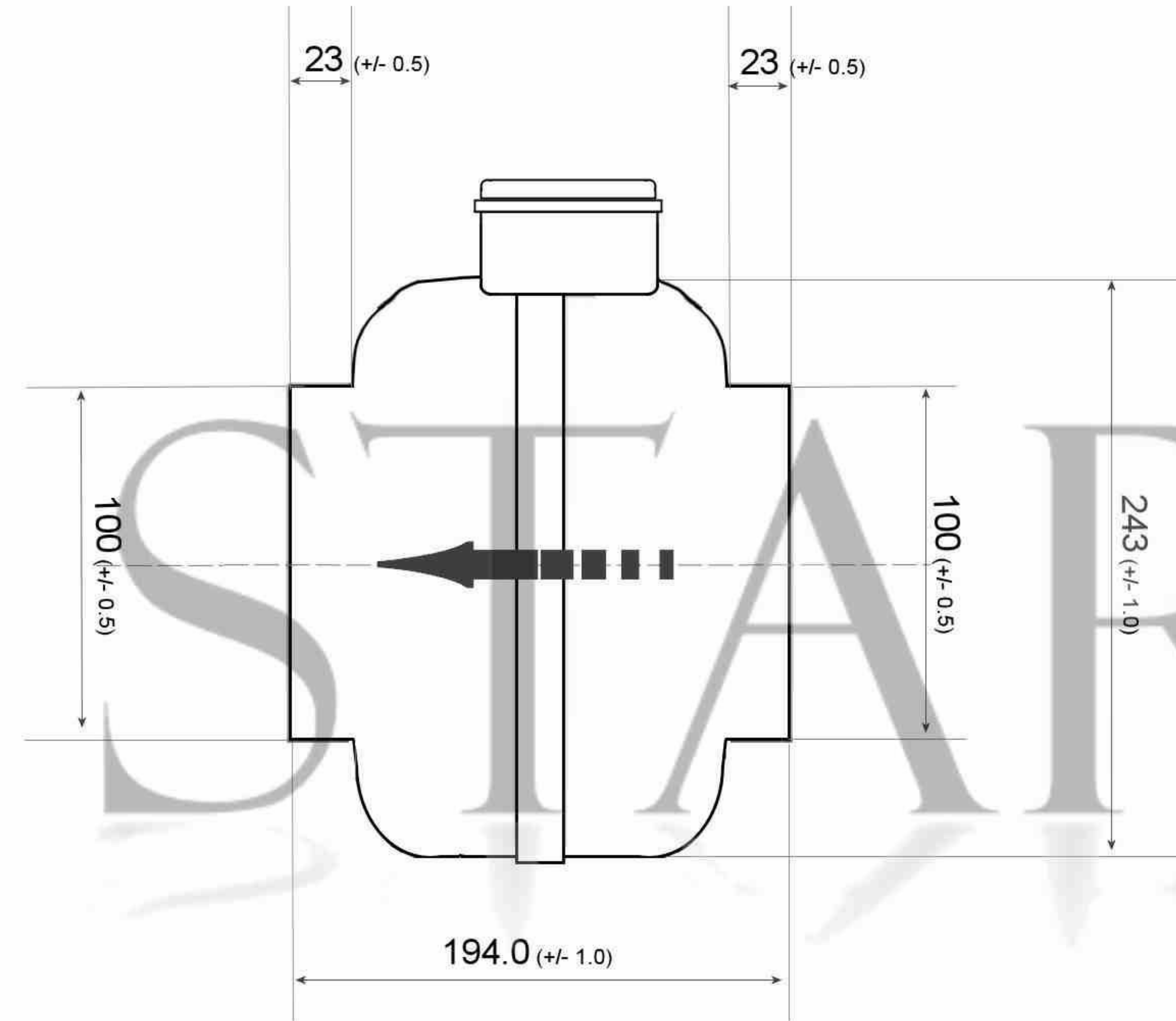

POLE STAR PRODUCTS LIMITED

SPECIFICATION

Motor	PSC	Speed (RPM)	2360	Bearings	Ball
Voltage (V)	220	Motor Protection	Th.Prot.	Weight (Kg)	3.0
Frequency (Hz)	50	Insulation Class	B	Volume M2/h	290
Power In/Out (W)	62	Protection Class	IP44	Static Pres. (Pa)	350
Current (A)	0.35	Capacitor (MF)	3.0	Noise (dBA)	47

All sizes in millimeters unless otherwise stated

POLE STAR
PRODUCTS LIMITED

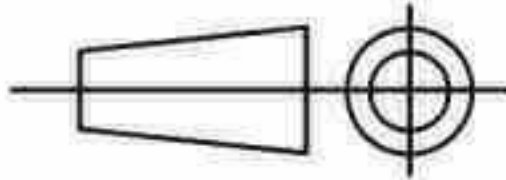
POLE STAR PRODUCTS LIMITED	
Product Code ILDF2-100	
Projection Angle ± 3°	
A4	
Scale: Sheet: 1 of	