

Wheel Size: 220 x 44

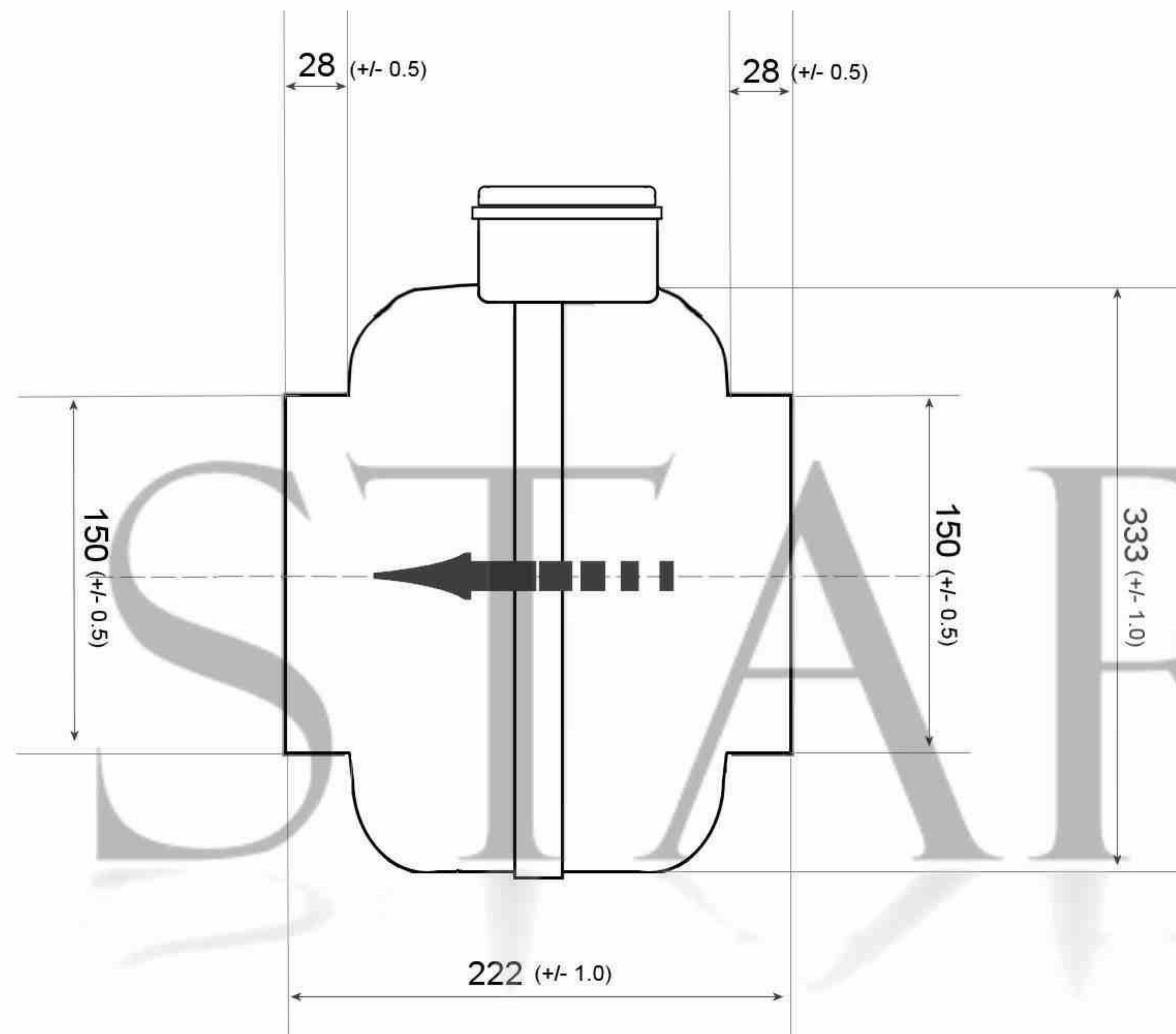

POLE STAR PRODUCTS LIMITED

SPECIFICATION

Motor	PSC	Speed (RPM)	2480	Bearings	Ball
Voltage (V)	220	Motor Protection	Th.Prot.	Weight (Kg)	5
Frequency (Hz)	50	Insulation Class	B	Volume M2/h	720
Power In/Out (W)	95	Protection Class	IP44	Static Pres. (Pa)	338
Current (A)	0.42	Capacitor (MF)	4.0	Noise (dBA)	52

All sizes in millimeters unless otherwise stated

POLE STAR PRODUCTS LIMITED

Product Code

ILDF2-150

Projection Angle
± 3°

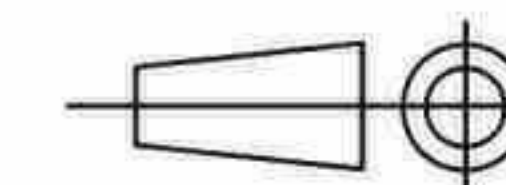

A4

Scale:

Sheet: 1 of

POLE STAR
PRODUCTS LIMITED