

Wheel Size: 250 x 40

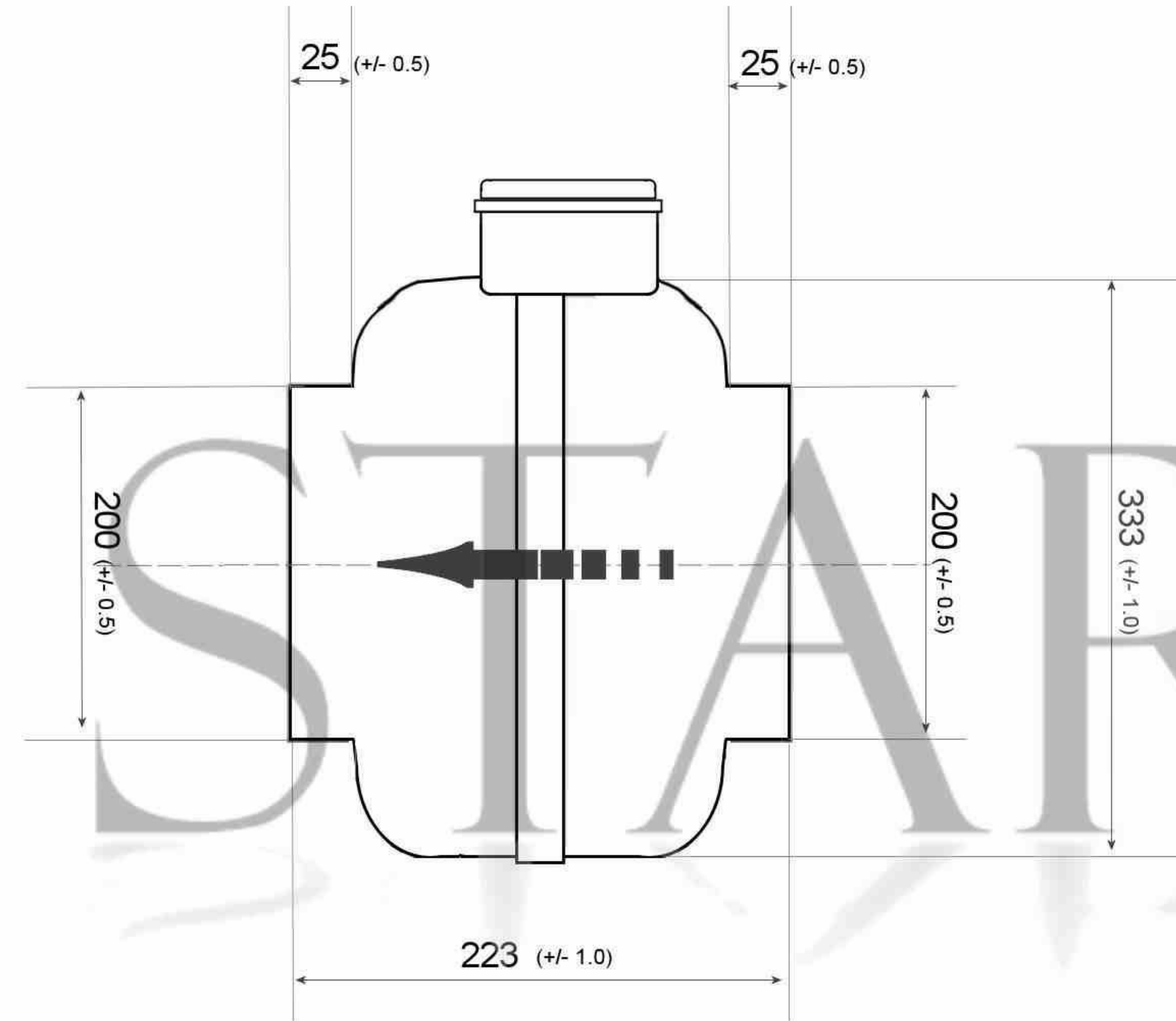

POLE STAR PRODUCTS LIMITED

SPECIFICATION

Motor	PSC	Speed (RPM)	2590	Bearings	Ball
Voltage (V)	220	Motor Protection	Th.Prot.	Weight (Kg)	5
Frequency (Hz)	50	Insulation Class	B	Volume M2/h	1000
Power In/Out (W)	138	Protection Class	IP44	Static Pres. (Pa)	610
Current (A)	0.61	Capacitor (MF)	4.0	Noise (dBA)	53

All sizes in millimeters unless otherwise stated

**POLE STAR**  
PRODUCTS LIMITED

POLE STAR PRODUCTS LIMITED

Product Code  
**ILDF2-200**

Projection Angle  
± 3°

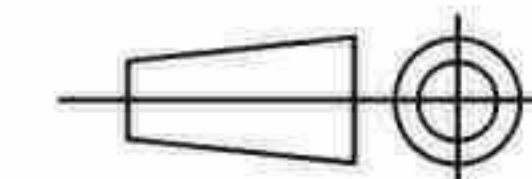

A4  
Scale:  
Sheet: 1 of