

Wheel Size:

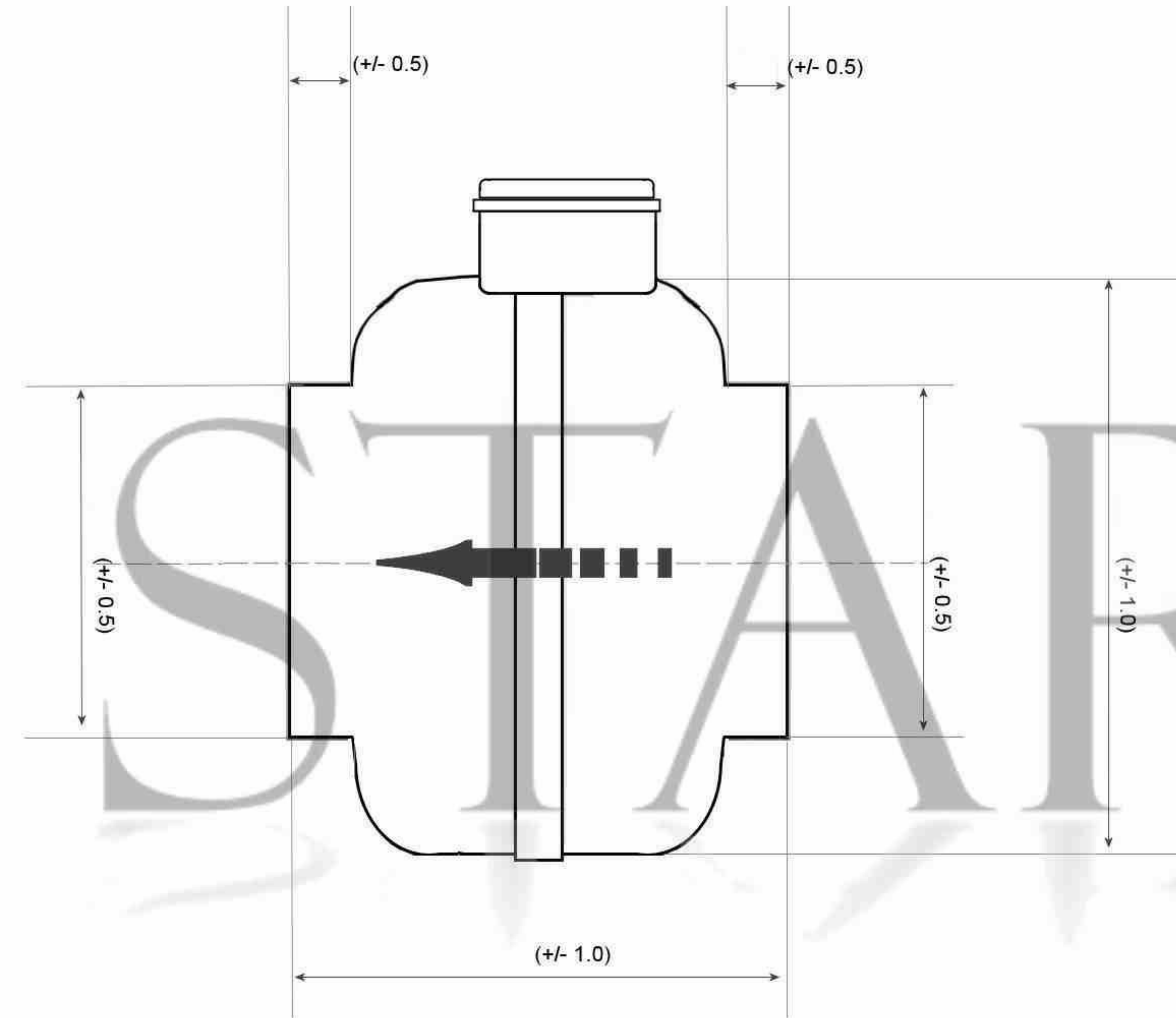

POLE STAR PRODUCTS LIMITED

SPECIFICATION					
Motor	PSC	Speed (RPM)	2390	Bearings	Ball
Voltage (V)	220	Motor Protection	Th.Prot.	Weight (Kg)	6.0
Frequency (Hz)	50	Insulation Class	B	Volume M2/h	1105
Power In/Out (W)	164	Protection Class	IP44	Static Pres. (Pa)	588
Current (A)	0.8	Capacitor (MF)	6.0	Noise (dBA)	55

All sizes in millimeters unless otherwise stated

POLE STAR
PRODUCTS LIMITED

POLE STAR PRODUCTS LIMITED	
Product Code	ILDF2-250
Projection Angle	± 3°
Scale:	A4
Sheet: 1 of	