

Wheel Size: 280 x 50

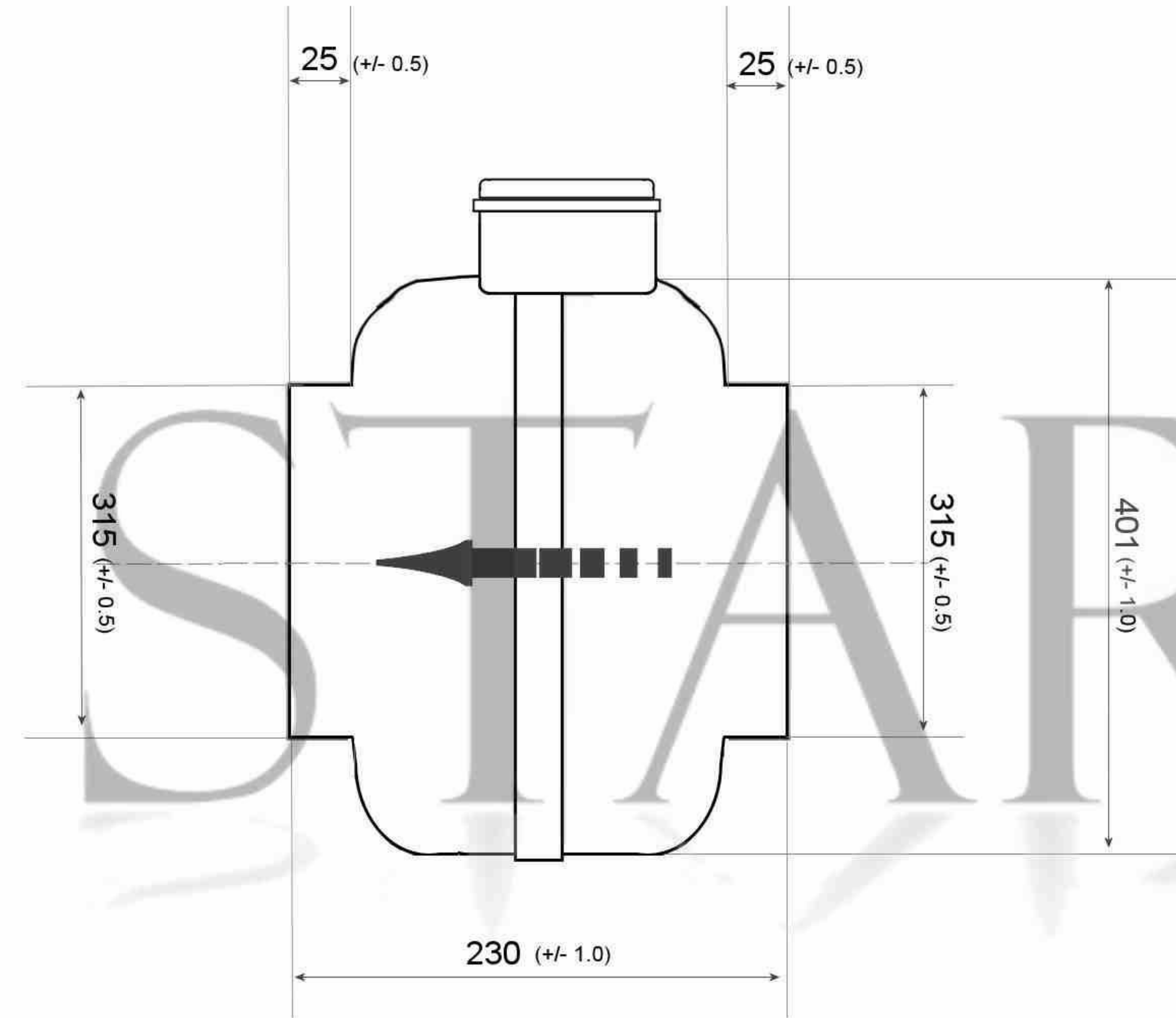

POLE STAR PRODUCTS LIMITED

SPECIFICATION

Motor	PSC	Speed (RPM)	2400	Bearings	Ball
Voltage (V)	220	Motor Protection	Th.Prot.	Weight (Kg)	8
Frequency (Hz)	50	Insulation Class	B	Volume M2/h	1875
Power In/Out (W)	225	Protection Class	IP44	Static Pres. (Pa)	704
Current (A)	1.05	Capacitor (MF)	6.0	Noise (dBA)	56

All sizes in millimeters unless otherwise stated

POLE STAR PRODUCTS LIMITED

Product Code  
**ILDF2-315**

**POLE STAR**  
PRODUCTS LIMITED

Projection Angle  
± 3°

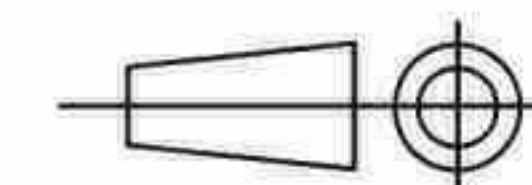

A4  
Scale:  
Sheet: 1 of