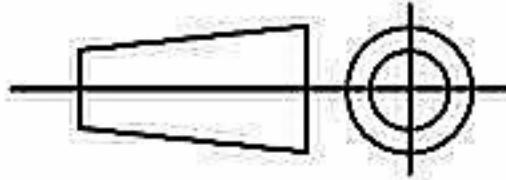

SPECIFICATION			
Motor	Speed (RPM)	Bearings	
Voltage (V)	Motor Protection	Weight (Kg)	
Frequency (Hz)	Insulation Class	Air Volume (M ³ /h)	
Power In/Out (W)	Protection Class	Noise Level (dBA)	
Current (A)	Capacitor (Mf)	Pressure (Pa)	

POLE STAR
PRODUCTS LIMITED

POLE STAR PRODUCTS LIMITED	
Product Code	RB-300M
Projection Angle $\pm 3^\circ$	
	A4
	Scale: Sheet: 1 of