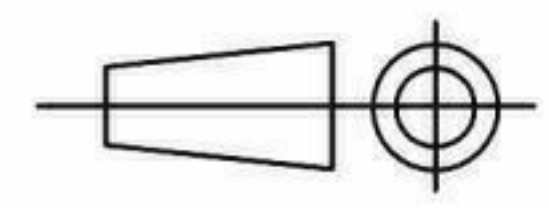

SPECIFICATION			
Motor	Speed (RPM)	Bearings	
Voltage (V)	Motor Protection	Weight (Kg)	
Frequency (Hz)	Insulation Class	Air Volume (M <sup>3</sup> /h)	
Power In/Out (W)	Protection Class	Noise Level (dBA)	
Current (A)	Capacitor (Mf)	Pressure (Pa)	

**POLE STAR**  
PRODUCTS LIMITED

POLE STAR PRODUCTS LIMITED	
Product Code	<b>RD-200M</b>
Projection Angle ± 3°	
	A4
	Scale: Sheet: 1 of