

**Accessories - DD7F (Mounting Feet)**

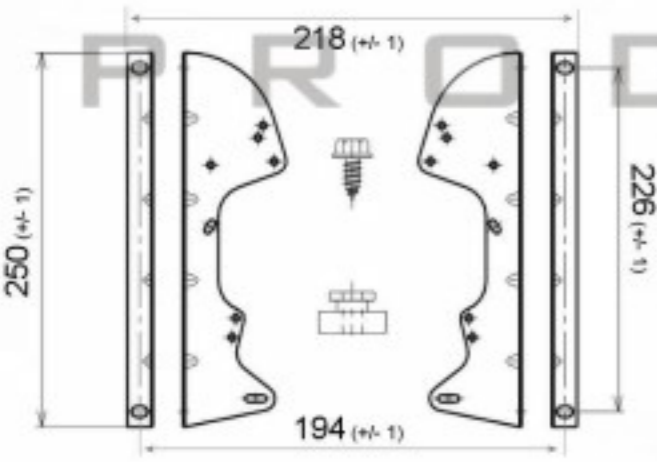

**Accessories - DDF7/5 (Flange)**

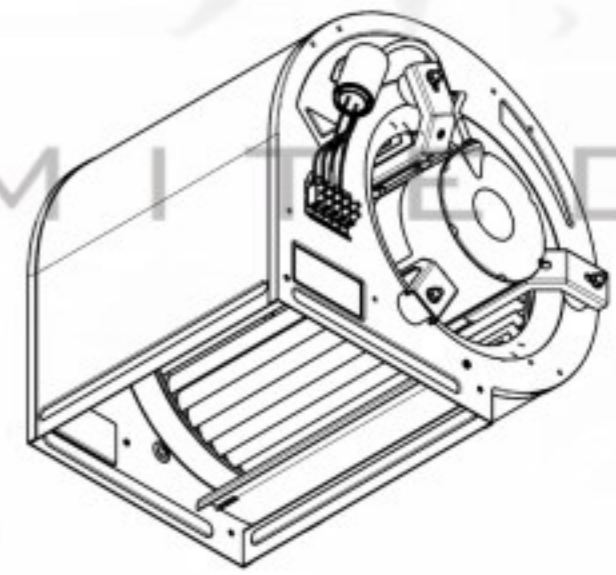
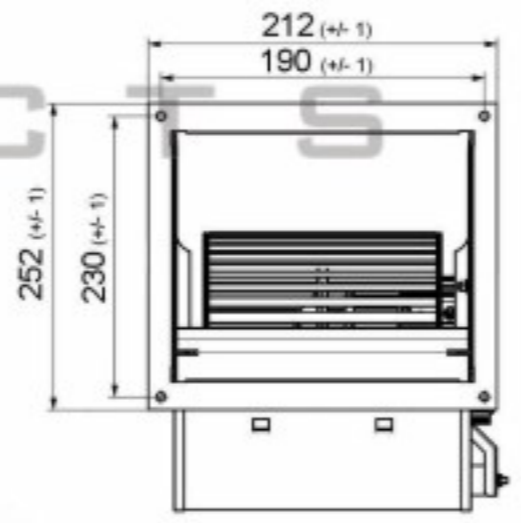

SPECIFICATION					
Motor	PSC	Speed (RPM)	850	Bearings	Ball
Voltage (V)	230/240	Motor Protection	Th.Prot	Weight (Kg)	8.0
Frequency (Hz)	50/60	Insulation Class	B	Air Volume (M <sup>3</sup> /h)	900
Power In/Out (W)	75	Protection Class	IP42	Noise Level (dBA)	
Current (A)	0.67	Capacitor (Mf)	5.0	Pressure (Pa)	41

**POLE STAR**  
PRODUCTS LIMITED

POLE STAR PRODUCTS LIMITED	
Product Code	<b>DD7/5-S75/1V-1</b>
Projection Angle	± 3°
	A4
	Scale:
	Sheet: 1 of