

Accessories - DDF7/7 (Flange)

Accessories - DD7F (Mounting Feet)

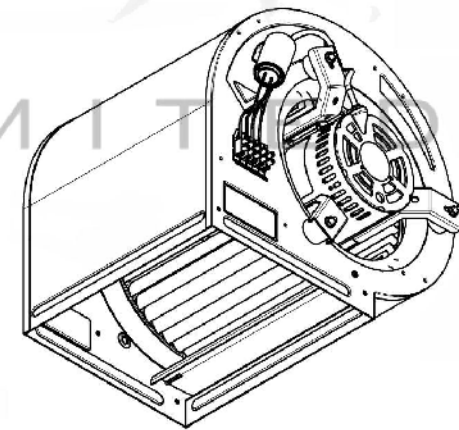
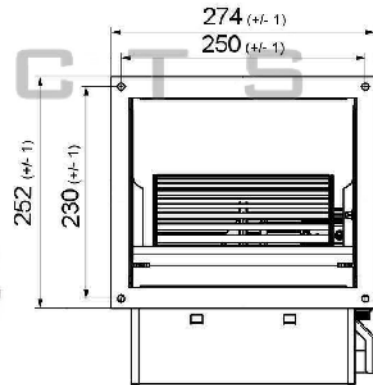
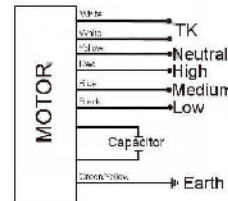
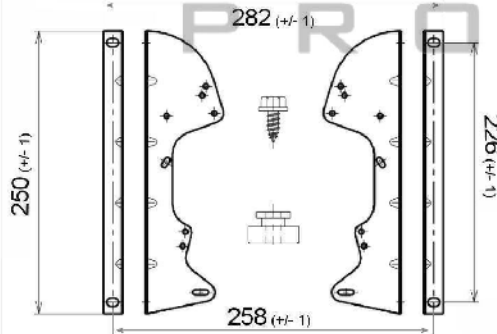

SPECIFICATION

Motor	PSC	Speed (RPM)	1200	Bearings	Ball
Voltage (V)	230/240	Motor Protection	Th.Prot	Weight (Kg)	
Frequency (Hz)	50/60	Insulation Class	B	Air Volume (MF/h)	
Power In/Out (W)	150	Protection Class	IP42	Noise Level (dBA)	
Current (A)	1.2	Capacitor (Mf)	6.0	Pressure (Pa)	0

POLE STAR
PRODUCTS LIMITED

POLE STAR PRODUCTS LIMITED

Product Code
DD7/7-F150/3V-1

Projection Angle
± 3°

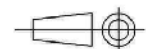

Scale: A4
Sheet: 1 of 1