

Accessories - DDF7/7 (Flange)

Accessories - DD7F (Mounting Feet)

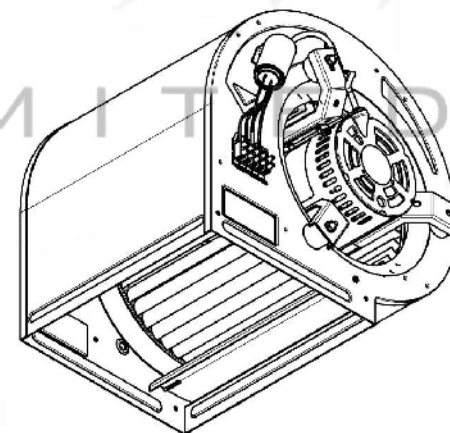
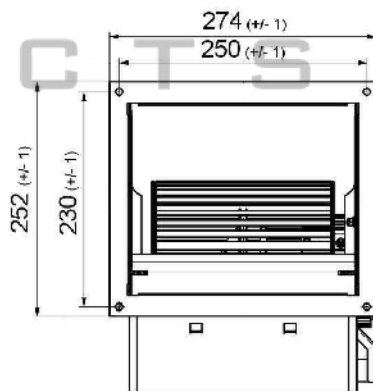
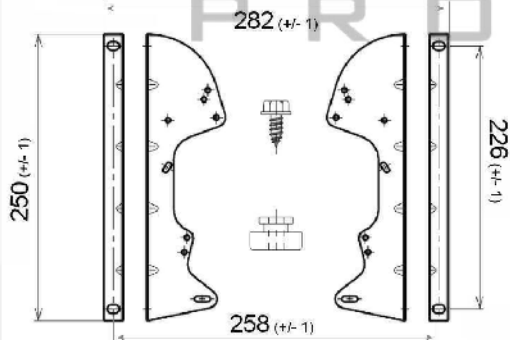

SPECIFICATION					
Motor	PSC	Speed (RPM)	1250	Bearings	Ball
Voltage (V)	230/240	Motor Protection	Th.Prot	Weight (Kg)	7.5
Frequency (Hz)	50/60	Insulation Class	B	Air Volume (M ³ /h)	830
Power In/Out (W)	50	Protection Class	IP42	Noise Level (dBA)	
Current (A)	0.65	Capacitor (Mf)	2.5	Pressure (Pa)	41

POLE STAR
PRODUCTS LIMITED

POLE STAR PRODUCTS LIMITED	
Product Code	DD7/7-F50/1V-1
Projection	A4
Angle	Scale:
± 3°	Sheet: 1 of

