

**Accessories - DD9/7 (Flange)**

**Accessories - DD9F (Mounting Feet)**

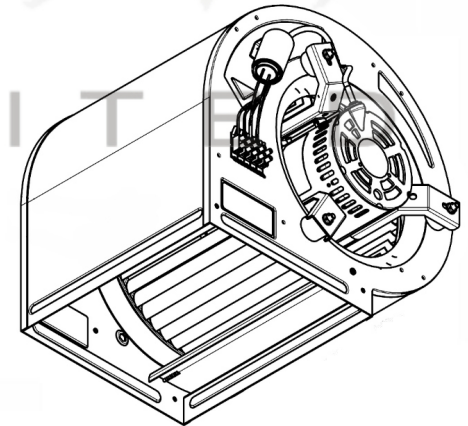
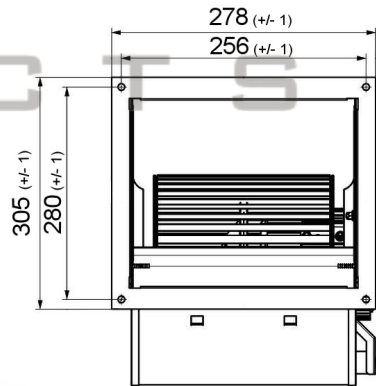
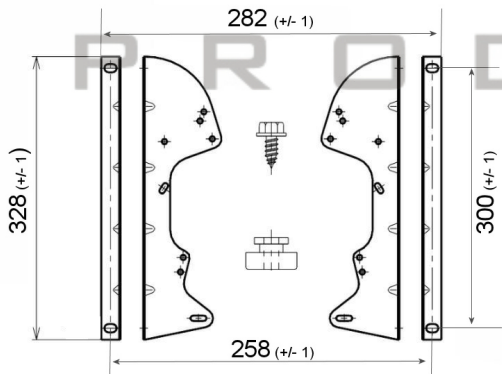

SPECIFICATION					
Motor	PSC	Speed (RPM)	1250	Bearings	Ball
Voltage (V)	230/240	Motor Protection	Th.Prot	Weight (Kg)	13.5
Frequency (Hz)	50/60	Insulation Class	B	Air Volume (M <sup>3</sup> /h)	2100
Power In/Out (W)	150	Protection Class	IP42	Noise Level (dBA)	
Current (A)	1.2	Capacitor (Mf)	5.0	Pressure (Pa)	40.2

**POLE STAR**  
PRODUCTS LIMITED

POLE STAR PRODUCTS LIMITED	
Product Code	
<b>DD9/7-F150/1V-1</b>	
Projection	A4
Angle	Scale:
± 3°	Sheet: 1 of

