

**Accessories - DD9/7 (Flange)**

**Accessories - DD9F (Mounting Feet)**

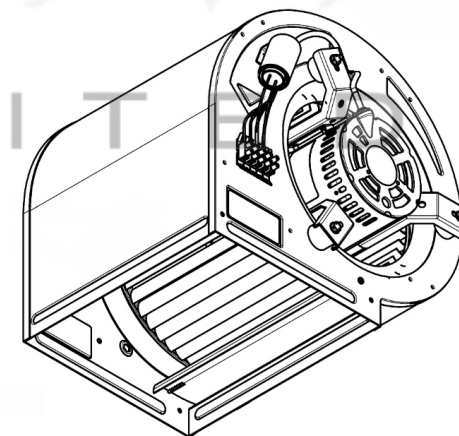
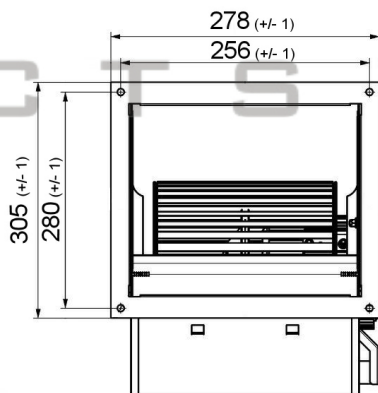
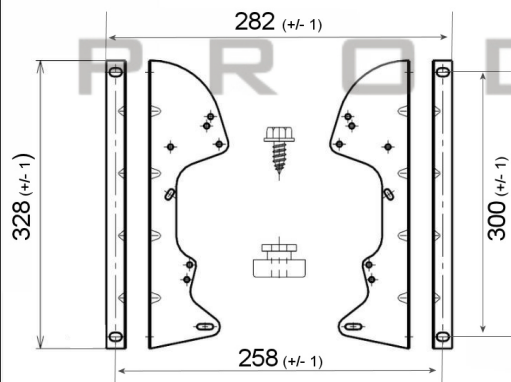

**SPECIFICATION**

Motor	PSC	Speed (RPM)	1250	Bearings	Ball
Voltage (V)	230/240	Motor Protection	Th.Prot	Weight (Kg)	13.7
Frequency (Hz)	50/60	Insulation Class	B	Air Volume (M³/h)	2300
Power In/Out (W)	200	Protection Class	IP42	Noise Level (dBA)	
Current (A)	1.7	Capacitor (Mf)	5.0	Pressure (Pa)	40.2

**POLE STAR**  
PRODUCTS LIMITED

POLE STAR PRODUCTS LIMITED

Product Code  
**DD9/7-F200/1V-1**

Projection  
Angle  
± 3°



A4  
Scale:  
Sheet: 1 of