

Accessories - DD9F (Mounting Feet)

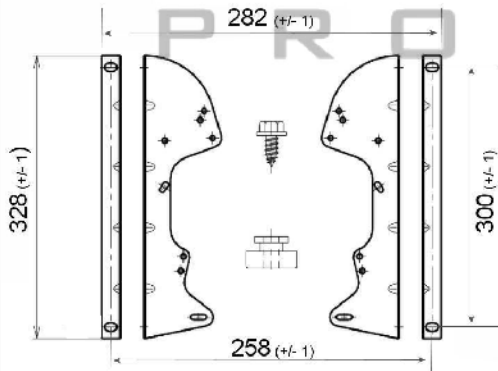

Accessories - DD9/7 (Flange)

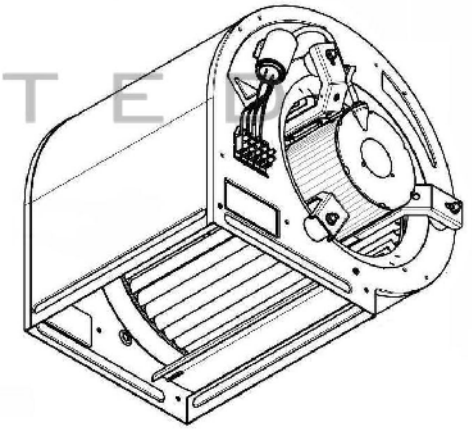
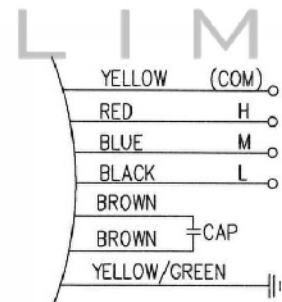
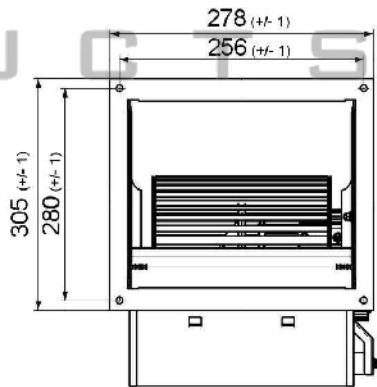

SPECIFICATION					
Motor	PSC	Speed (RPM)	900	Bearings	Ball
Voltage (V)	230/240	Motor Protection	Th.Prot	Weight (Kg)	
Frequency (Hz)	50/60	Insulation Class	B	Air Volume (M ³ /h)	
Power In/Out (W)	185	Protection Class		Noise Level (dBA)	
Current (A)		Capacitor (Mf)	12	Pressure (Pa)	

POLE STAR
PRODUCTS LIMITED

POLE STAR PRODUCTS LIMITED	
Product Code DD9/7-S185/3V-1	
Projection Angle ± 3°	
Scale:	A4
	Sheet: 1 of