

Accessories - DD9/7 (Flange)

Accessories - DD9F (Mounting Feet)

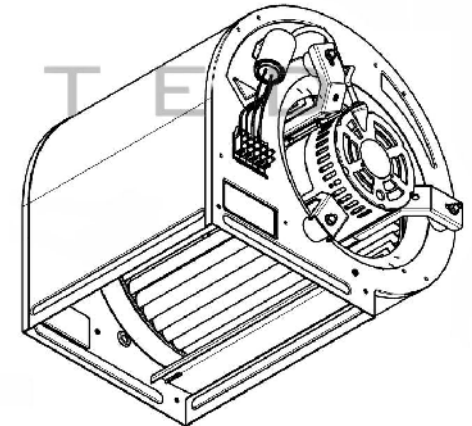
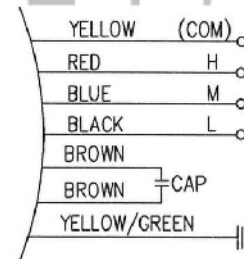
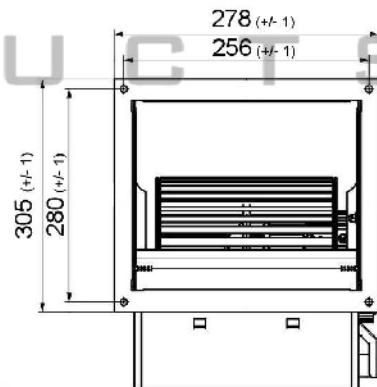
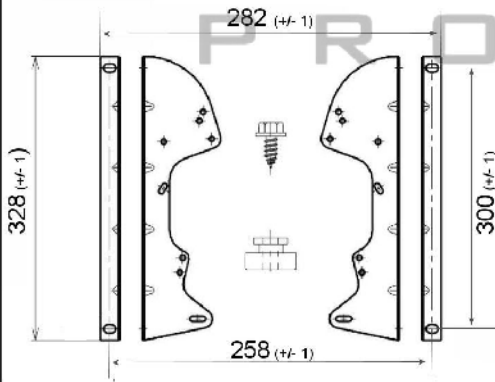

SPECIFICATION

Motor	PSC	Speed (RPM)	850	Bearings	Ball
Voltage (V)	230/240	Motor Protection	Th.Prot	Weight (Kg)	17.0
Frequency (Hz)	50/60	Insulation Class	B	Air Volume (M³/h)	3150
Power In/Out (W)	335	Protection Class	IP42	Noise Level (dBA)	
Current (A)	2.6	Capacitor (Mf)	8.0	Pressure (Pa)	0.00

POLE STAR
PRODUCTS LIMITED

POLE STAR PRODUCTS LIMITED

Product Code
DD9/7-S335/1V-1

Projection	A4
Angle	Scale:
± 3°	Sheet: 1 of

