

All measurements shown are in millimeters

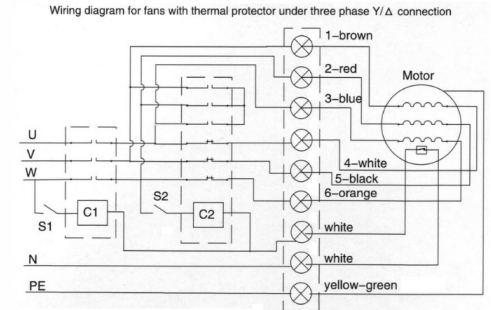

C1-Run control touch machine, connect S1, run fan.
C2-Y/Δ Control touch machine, S2 cut, Δ connection; S2 connect, Y connection.

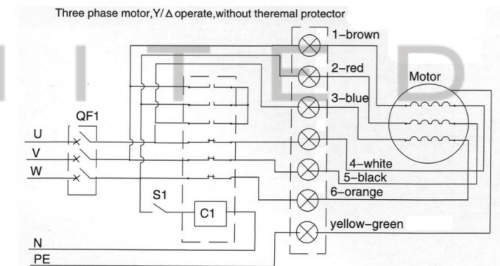
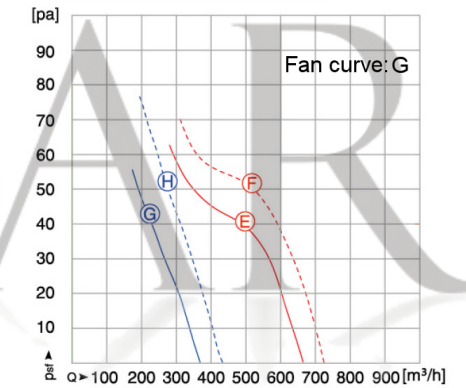

QF1-Run control air switch, connect QF1, fan start.
C1-Y/Δ Run control touch machine, cut S1, Δ connection, connect S1; Y connection.

SPECIFICATION					
Motor	PSC	Speed (RPM)	1443	Bearings	Ball
Voltage (V)	380	Motor Protection	Th. Prot.	Weight (Kg)	2.3
Frequency (Hz)	50/60	Insulation Class	B	Air Volume (M³/h)	
Power In/Out (W)	36	Protection Class	IP54	Noise Level (dBA)	53
Current (A)	0.14	Temp. Range	-30 +60	Capacitor (MF)	

POLE STAR
PRODUCTS LIMITED

POLE STAR PRODUCTS LIMITED	
Product Code GMA3-200B-2	
Projection Angle ± 3°	A4 Scale: Sheet: 1 of