

All measurements shown are in millimeters

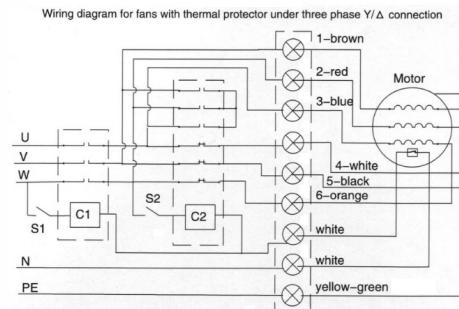

C1-Run control touch machine,connect S1,run fan.  
C2-Y/Δ Control touch machine,S2 cut, Δ connection;S2 connect,Y connection.

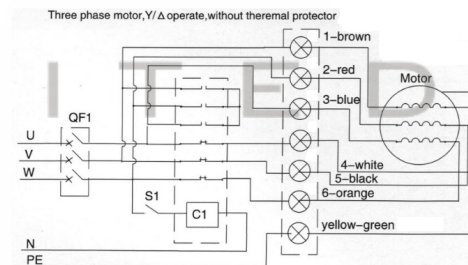
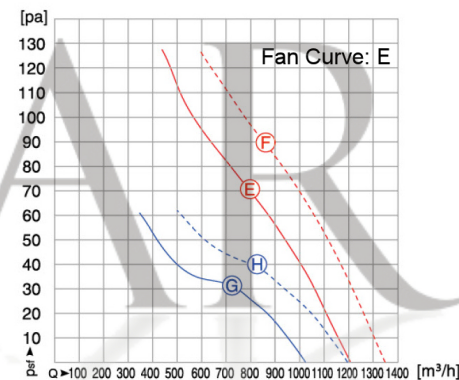

QF1-Run control air switch,connect QF1,fan start.  
C1-Y/Δ Run control touch machine,cut S1, Δ connection,connect S1;Yconnection.

SPECIFICATION					
Motor	PSC	Speed (RPM)	2616	Bearings	Ball
Voltage (V)	380	Motor Protection	Th. Prot.	Weight (Kg)	2.8
Frequency (Hz)	50/60	Insulation Class	B	Air Volume (M³/h)	
Power In/Out (W)	92	Protection Class	IP54	Noise Level (dBA)	68
Current (A)	0.24	Temp. Range	-30 +60	Capacitor (MF)	

**POLE STAR**  
PRODUCTS LIMITED

POLE STAR PRODUCTS LIMITED	
Product Code	<b>GMA3-250B-1</b>
Projection	A4
Angle	Scale:
± 3°	Sheet: 1 of