

Pump

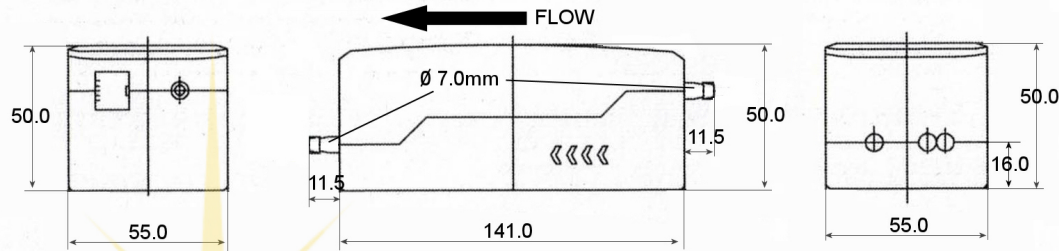

Reservoir

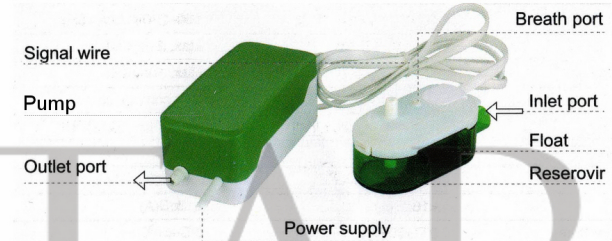
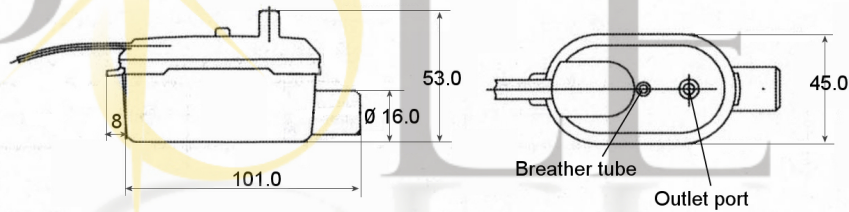

FLOW RATE:

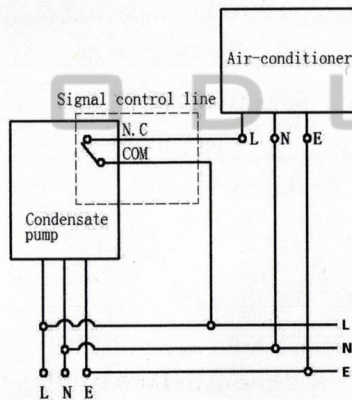
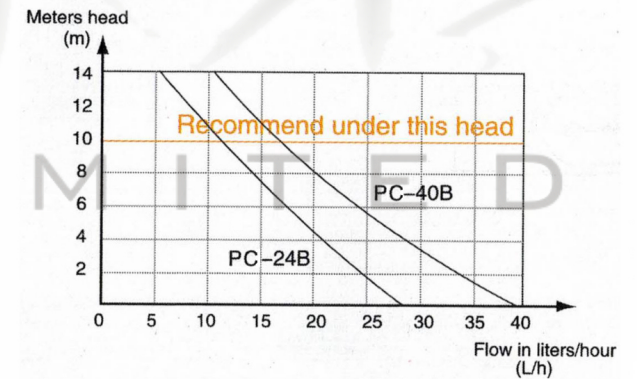

Power:
 (L) Live: Brown
 (N) Neutral: Blue
 Alarm/volt free:
 (N.C.)Normally closed :Black
 (COM.)Common:Black

NB: Not continuous duty

SPECIFICATION					
Motor	1Ph	Max. Lift	2 meters	Amb. Temp.	0°C - 50°C
Voltage (V)	100-230			Weight (Kg)	0.32
Frequency (Hz)	50/60	Flow Rate (L/H)	24	Noise dB(A)	16
Power In/Out (W)	3.0	Tank Capacity	55ml		
Current	50 mA	Discharge Head	10m		

POLE STAR
 PRODUCTS LIMITED

EC Condensate pump

POLE STAR PRODUCTS LIMITED	
Product Code	PC-24B
Projection Angle ± 3°	
	A4 Scale: Sheet: 1 of