

Model shown is left hand motor

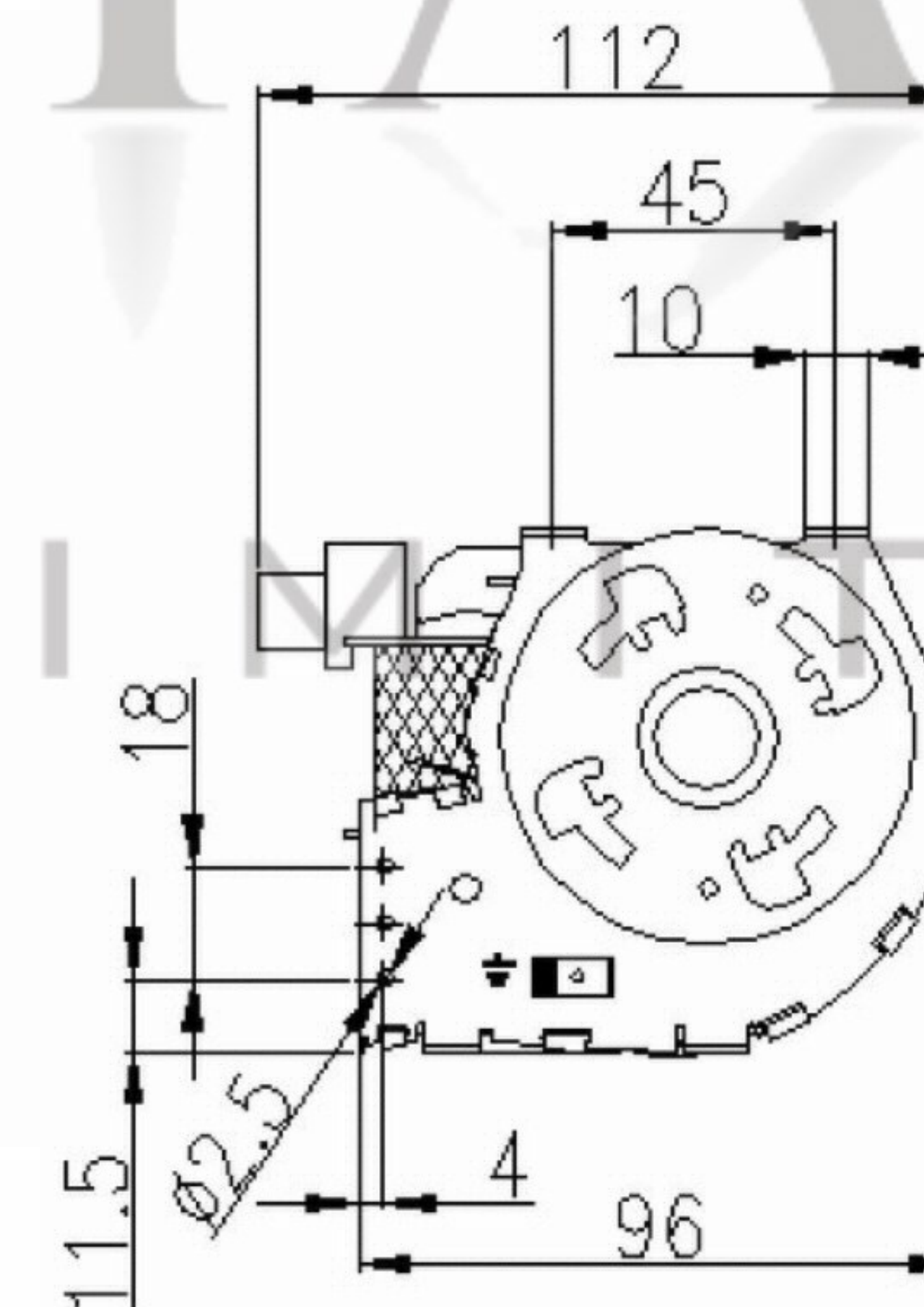
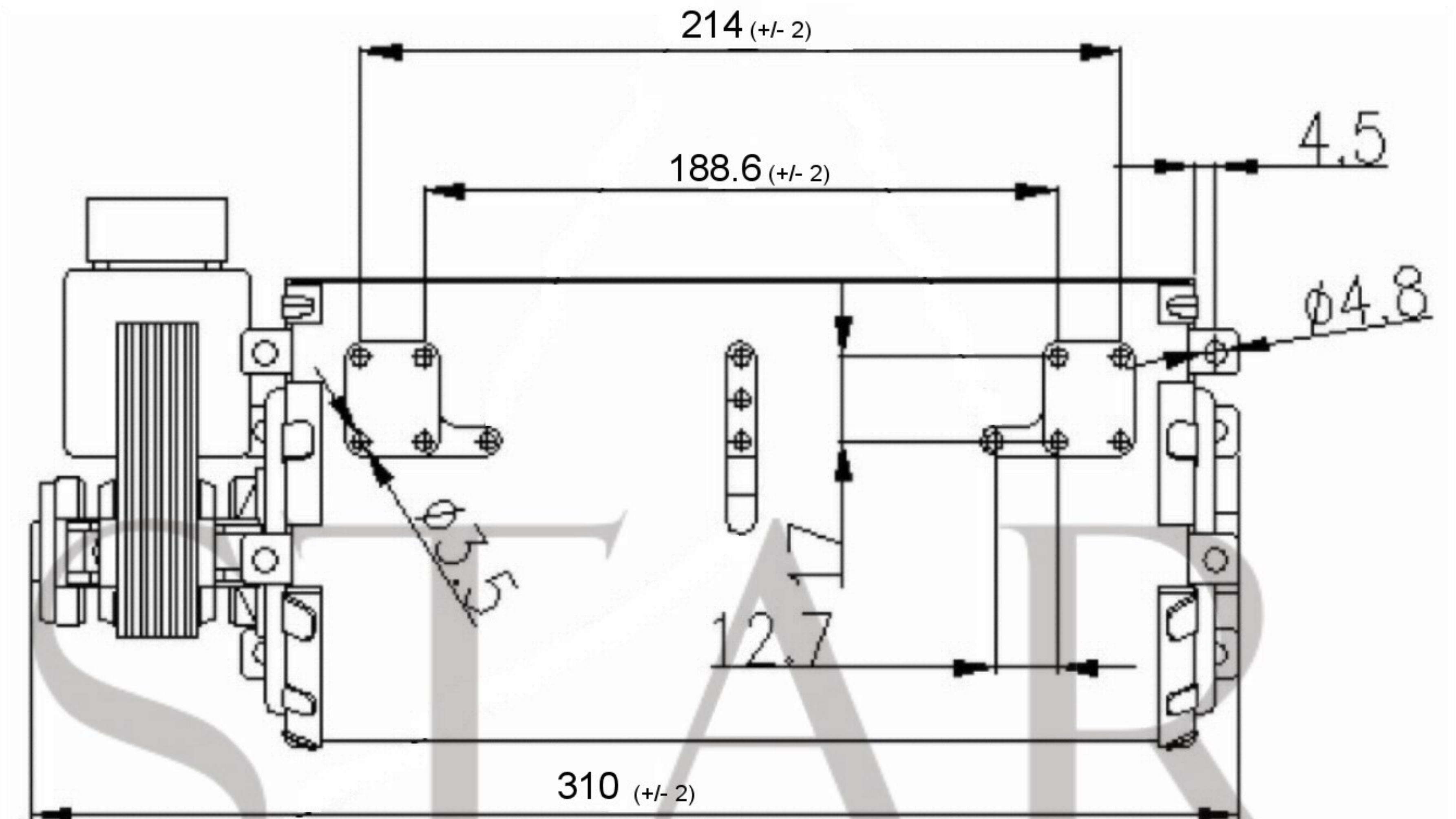
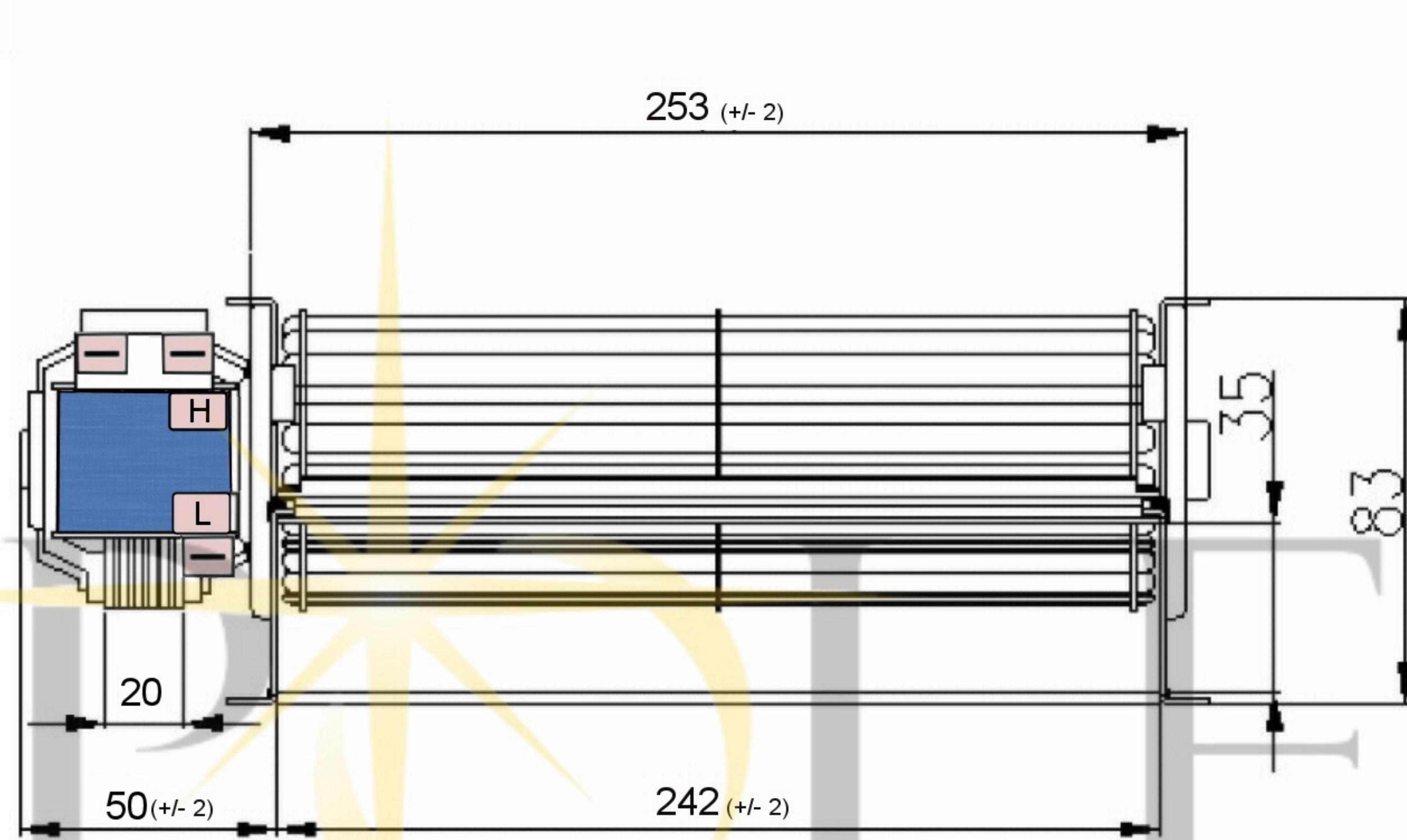

| SPECIFICATION | | Temp. Range: 0°C to + 60°C | | | |
|------------------|---------|----------------------------|-----------|-------------------|---------|
| Motor | SP | Speed (RPM) | 1500/1100 | Bearings | Sleeve |
| Voltage (V) | 230/240 | Motor Protection | Imp.Prot | Weight (Kg) | 1.0 |
| Frequency (Hz) | 50 | Insulation Class | B | Air Volume (M³/h) | 170/120 |
| Power In/Out (W) | 22/14 | Protection Class | IP20 | Noise Level (dBA) | |
| Current (A) | | | | Max Pressure (Pa) | 50 |

POLE STAR
PRODUCTS LIMITED

| | |
|----------------------------|-----------------|
| POLE STAR PRODUCTS LIMITED | |
| Product Code | TAS24-2V |
| Projection Angle | ± 3° |
| | |
| | A4 |
| | Scale: |
| | Sheet: 1 of |