

Model shown is left hand motor

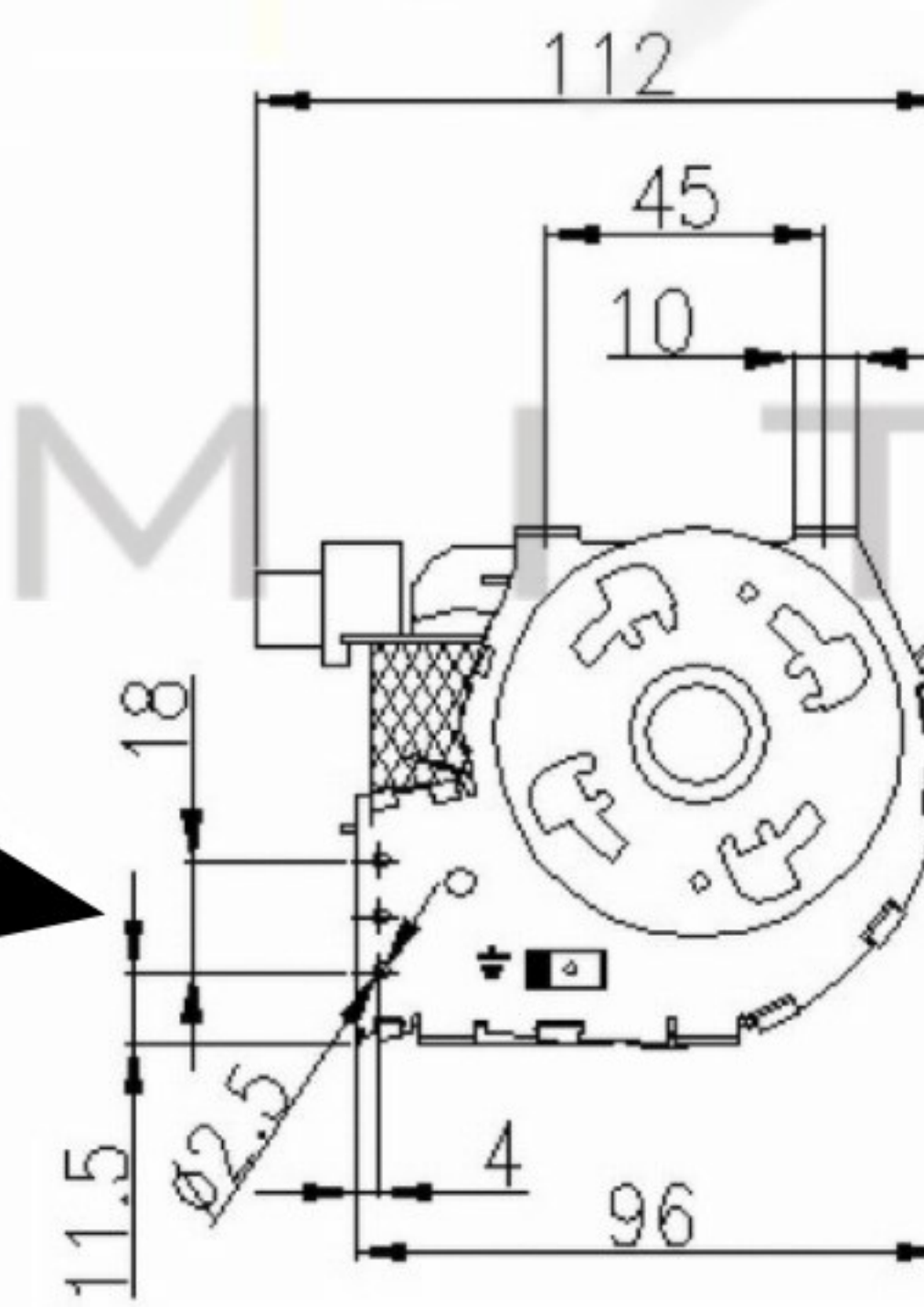
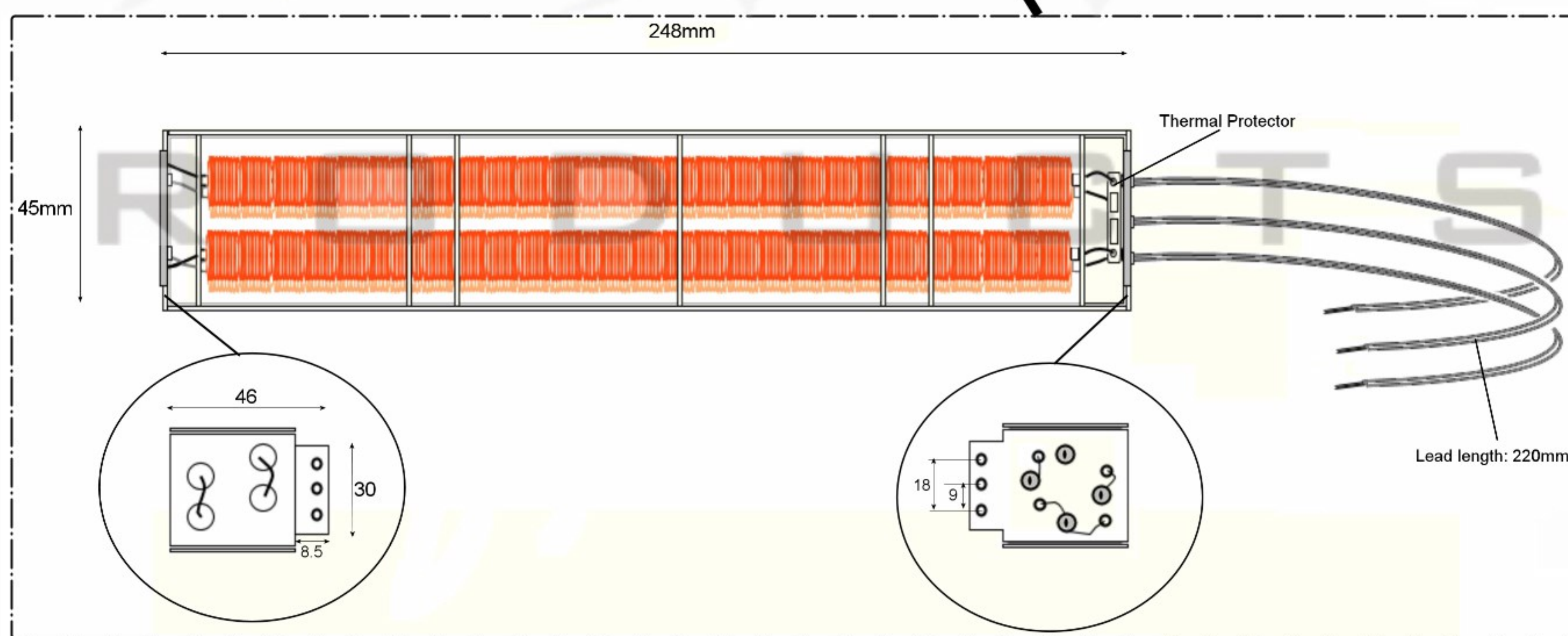
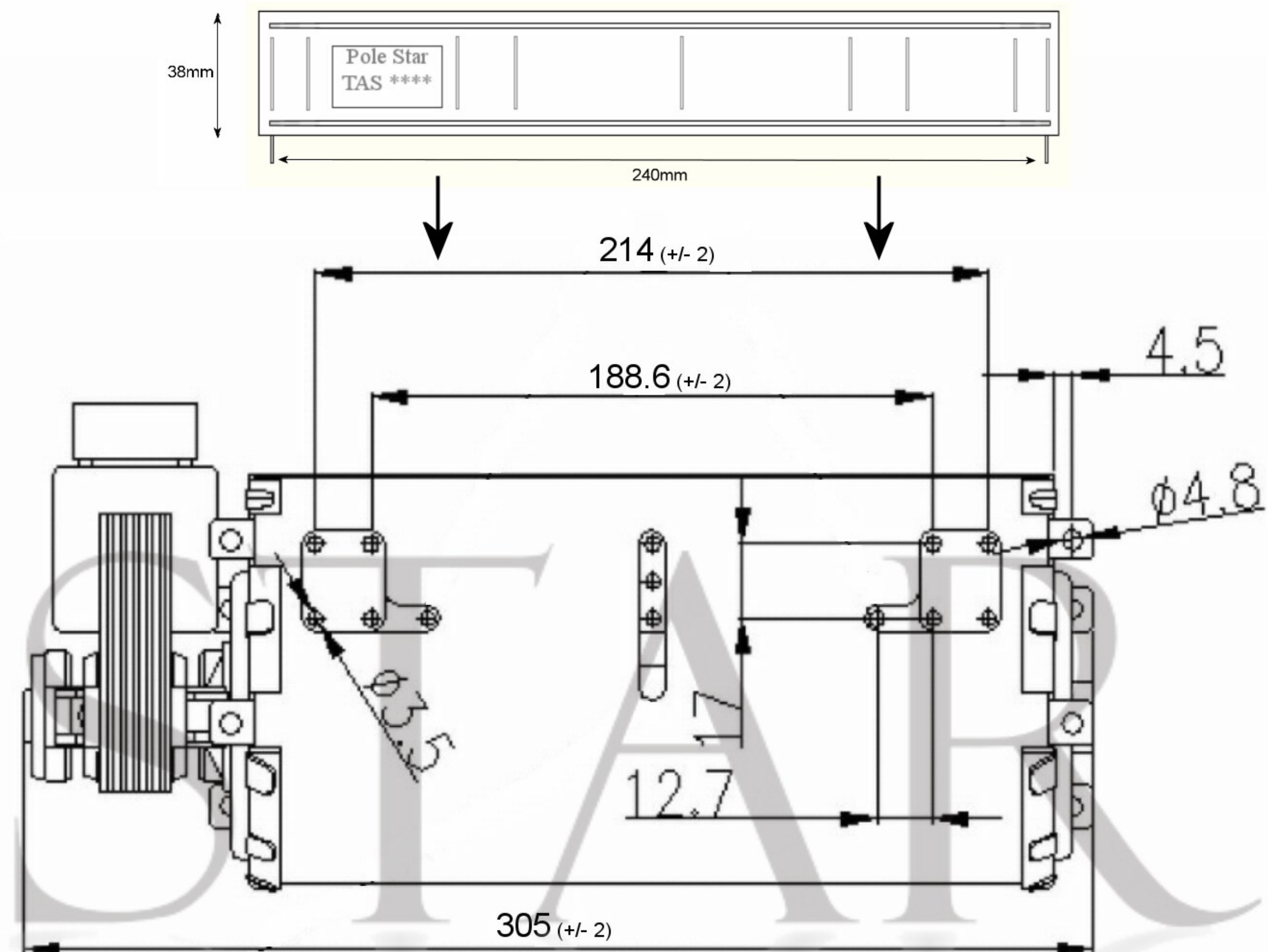
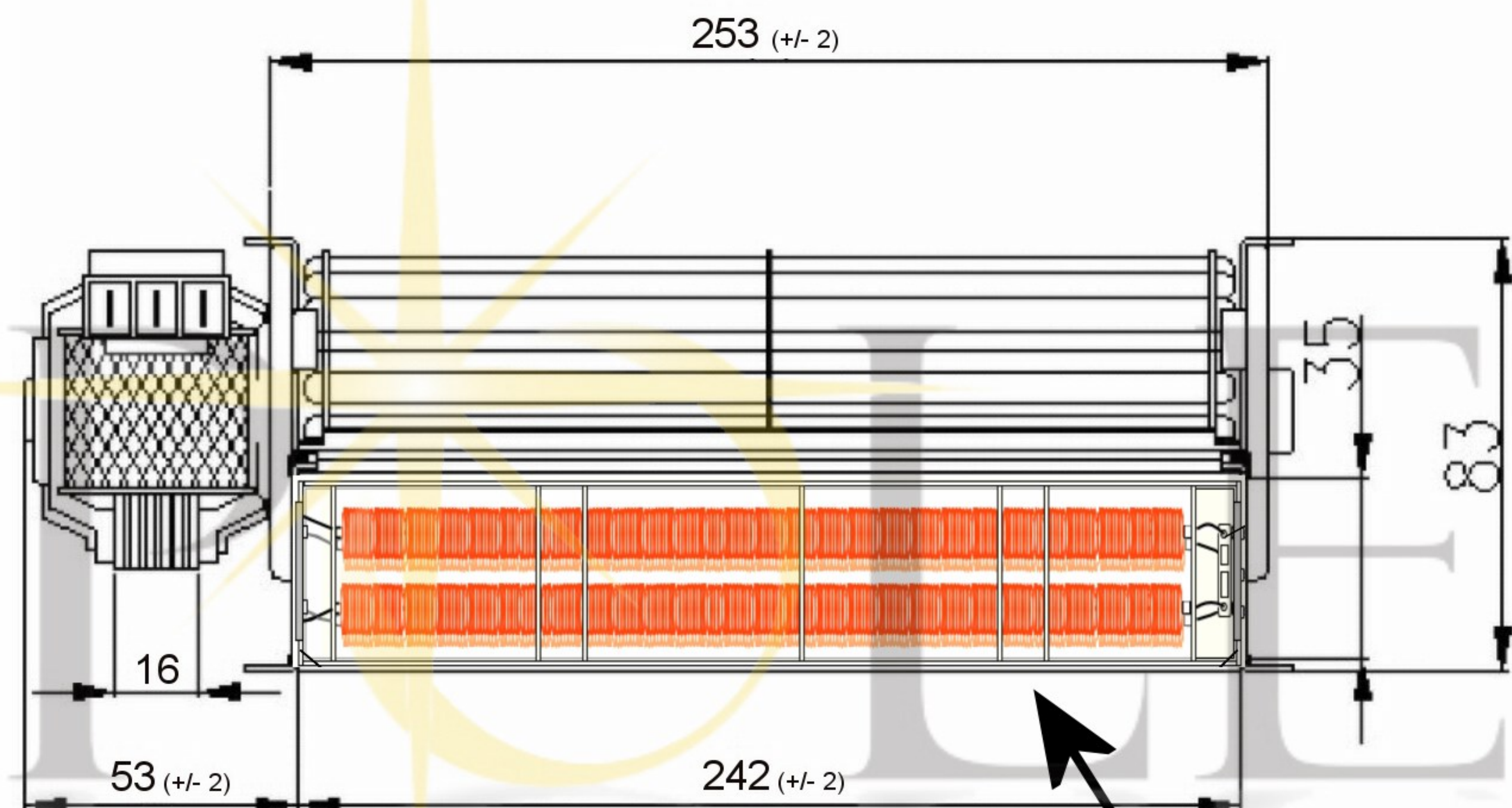

SPECIFICATION	Temp. Range: 0°C to + 60°C				
Motor	SHP	Speed (RPM)	1300	Bearings	Sleeve
Voltage (V)	230/240	Motor Protection	Imp.Prot	Weight (Kg)	1.0
Frequency (Hz)	50	Insulation Class	F	Air Volume (M³/h)	160
Power In/Out (W)	28	Protection Class	IP20	Heating Element	1.4Kw
Current (A)				Max Pressure (Pa)	50

POLE STAR
PRODUCTS LIMITED

POLE STAR PRODUCTS LIMITED	
Product Code	TAS24HE-1
Projection Angle	± 3°
	A4
	Scale:
	Sheet: 1 of