

		MM
A	Total Width	285
B	Fixing point width	14
C	Slot width	7
D	Fixing point lug outer PCD	260
E	Fixing point lug inner PCD	240
F	Fan blade diameter	200
G	Basket outer diameter	238
H	Basket inner diameter	230
I	Basket depth	45
J	Junction box protrusion	54
K	Fan blade/motor protrusion	21
L	Overall depth	120

All measurements shown are in millimeters
 Measurements shown have manufacturing tolerances of +/- 2mm

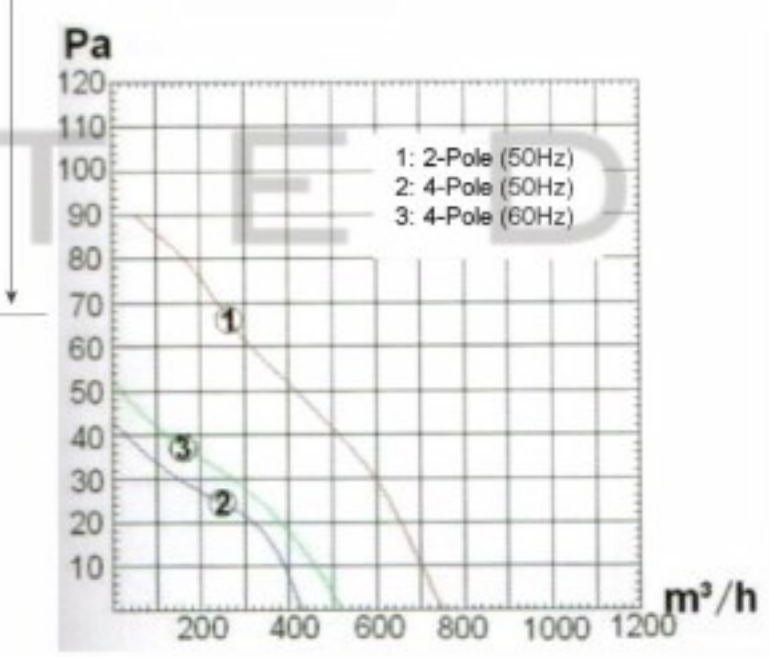
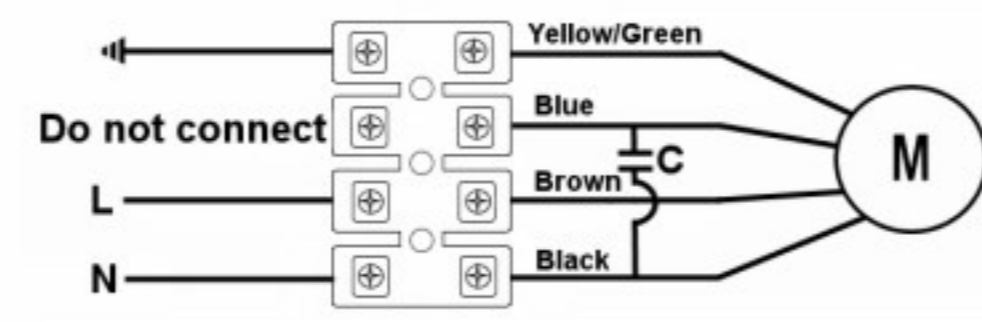

SPECIFICATION					
Motor	PSC	Speed (RPM)	2500	Bearings	Ball
Voltage (V)	220/240	Motor Protection	Th. Prot.	Weight (Kg)	2.5
Frequency (Hz)	50/60	Insulation Class	F	Air Volume (M³/h)	745
Power In/Out (W)	55	Protection Class	IP54	Noise Level (dBA)	52
Current (A)	0.25	Temp. Range	-30 +60	Capacitor (MF)	2.0

POLE STAR
 PRODUCTS LIMITED

POLE STAR PRODUCTS LIMITED
 Product Code **GMA1-200B2-1**
 Projection Angle ± 3°
 Scale: **A4**
 Sheet: 1 of 1