

		MM
A	Total Width	346
B	Fixing point width	16
C	Slot width	9
D	Fixing point lug outer PCD	334
E	Fixing point lug inner PCD	301
F	Fan blade diameter	248
G	Basket outer diameter	288
H	Basket inner diameter	277
I	Basket depth	60
J	Junction box protrusion	57
K	Fan blade/motor protrusion	23
L	Overall depth	140

All measurements shown are in millimeters
 Measurements shown have manufacturing tolerances of +/- 2mm

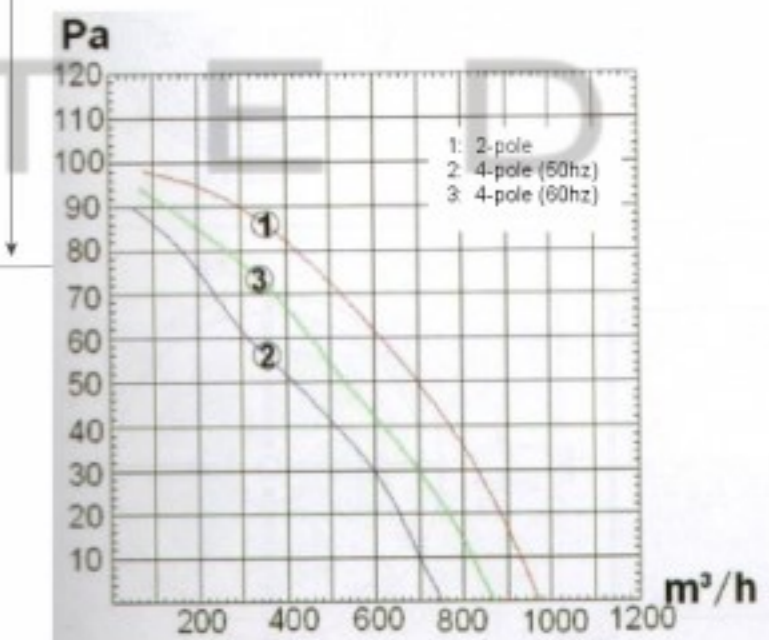
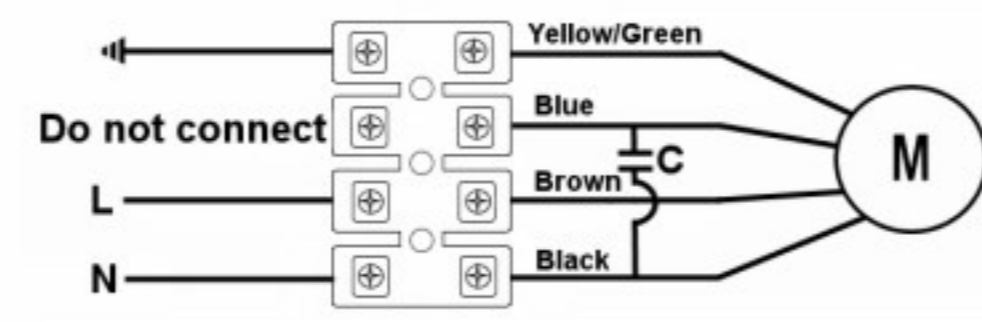

SPECIFICATION					
Motor	PSC	Speed (RPM)	2650	Bearings	Ball
Voltage (V)	220/240	Motor Protection	Th. Prot.	Weight (Kg)	3.0
Frequency (Hz)	50/60	Insulation Class	F	Air Volume (M³/h)	955
Power In/Out (W)	110	Protection Class	IP54	Noise Level (dBA)	60
Current (A)	0.5	Temp. Range	-30 +60	Capacitor (MF)	4.0

POLE STAR
 PRODUCTS LIMITED

POLE STAR PRODUCTS LIMITED

Product Code
GMA1-250B2-1

Projection Angle ± 3°

Scale: A4
 Sheet: 1 of 1