

A	Total Width	379
B	Fixing point width	15
C	Slot width	7
D	Fixing point lug outer PCD	366
E	Fixing point lug inner PCD	347
F	Fan blade diameter	300
G	Basket outer diameter	333
H	Basket inner diameter	322
I	Basket depth	80
J	Junction box protrusion	35
K	Fan blade/motor protrusion	35
L	Overall depth	150

All measurements shown are in millimeters
 Measurements shown have manufacturing tolerances of +/- 2mm

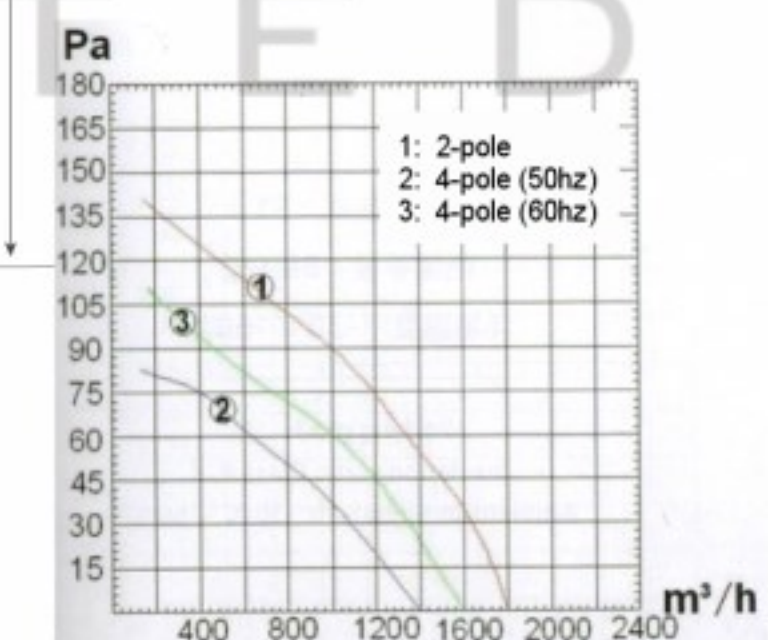
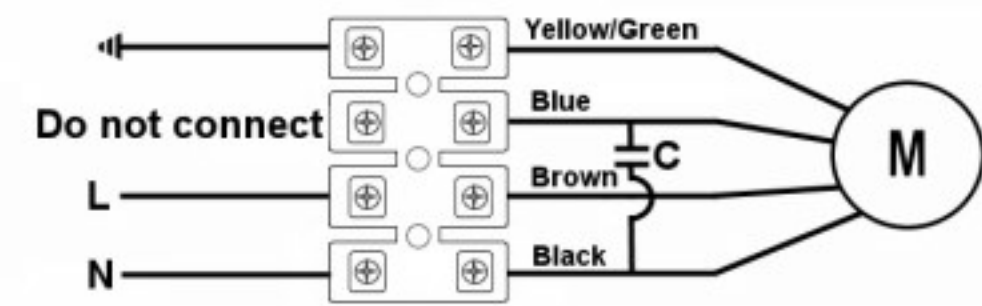

SPECIFICATION					
Motor	PSC	Speed (RPM)	1380	Bearings	Ball
Voltage (V)	220/240	Motor Protection	Th. Prot.	Weight (Kg)	3.3
Frequency (Hz)	50/60	Insulation Class	F	Air Volume (M³/h)	1400
Power In/Out (W)	80	Protection Class	IP54	Noise Level (dBA)	53
Current (A)	0.38	Temp. Range	-30 +60	Capacitor (MF)	3.0

POLE STAR
 PRODUCTS LIMITED

POLE STAR PRODUCTS LIMITED
 Product Code
GMA1-300S4-1

Projection Angle ± 3°

A4
 Scale:
 Sheet: 1 of