

Accessories - DD7F (Mounting Feet)

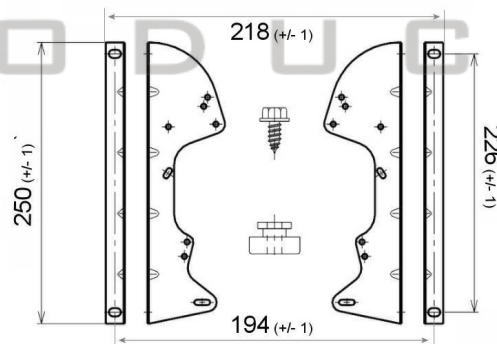

Accessories - DDF7/5 (Flange)

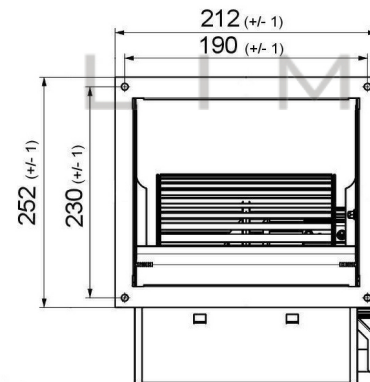

SPECIFICATION			
Motor	Speed (RPM)	Bearings	
Voltage (V)	Motor Protection	Weight (Kg)	
Frequency (Hz)	Insulation Class	Max Temp. Rise	
Power In/Out (W)	Protection Class	Amb. Temp	
Current (A)		High Pot Test	

POLE STAR
PRODUCTS LIMITED

Impellor:

POLE STAR PRODUCTS LIMITED

Product Code

DTA7/5

Projection
Angle
± 3°

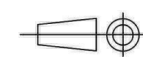

A4
Scale:
Sheet: 1 of