

A	Total Width	498
B	Fixing point width	20
C	Slot width	10
D	Fixing point lug outer PCD	476
E	Fixing point lug inner PCD	456
F	Fan blade diameter	397
G	Basket outer diameter	432
H	Basket inner diameter	423
I	Basket depth	90
J	Junction box protrusion	40
K	Fan blade/motor protrusion	55
L	Overall depth	185

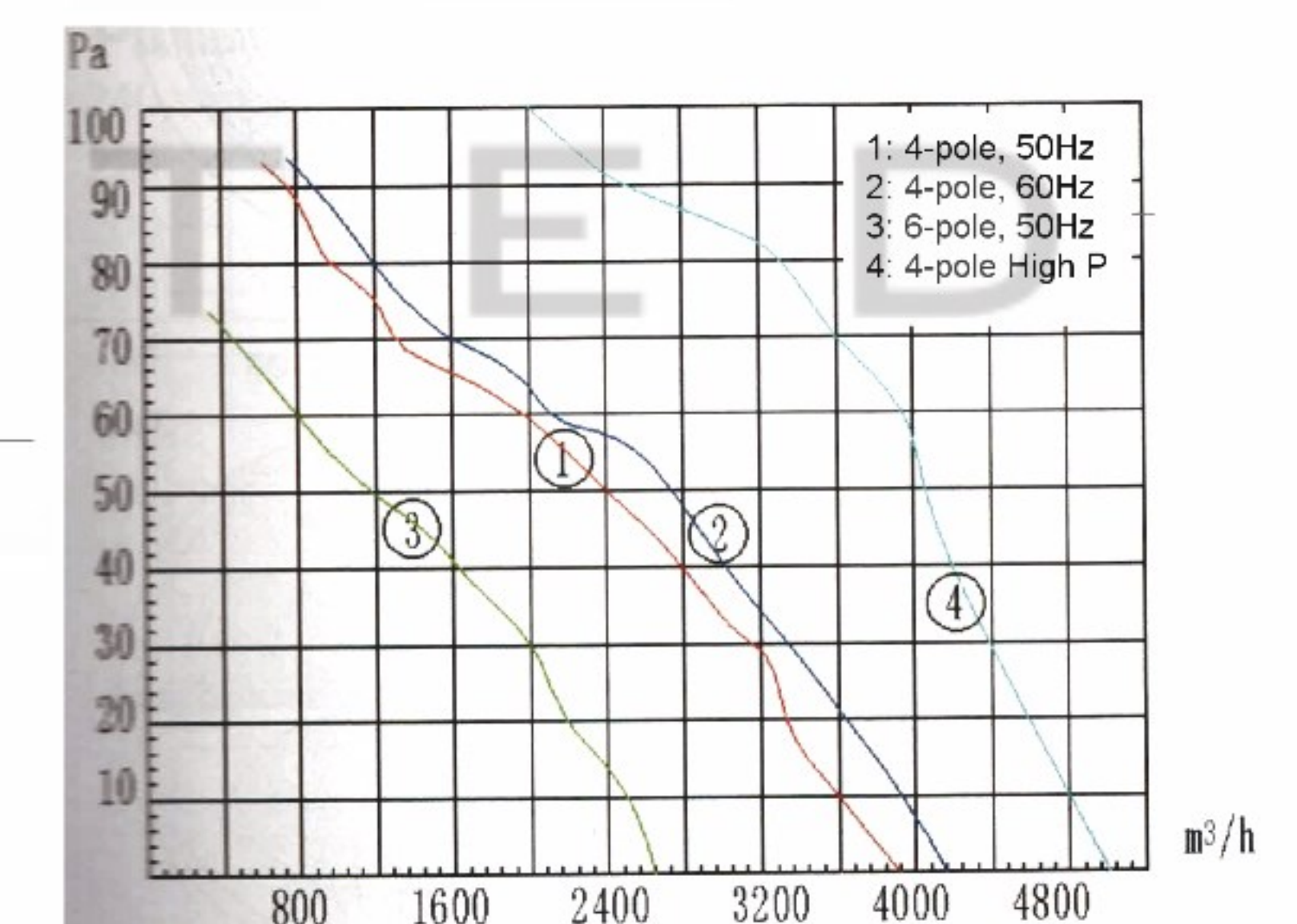

All measurements shown are in millimeters
 Measurements shown have manufacturing tolerances of +/- 2mm

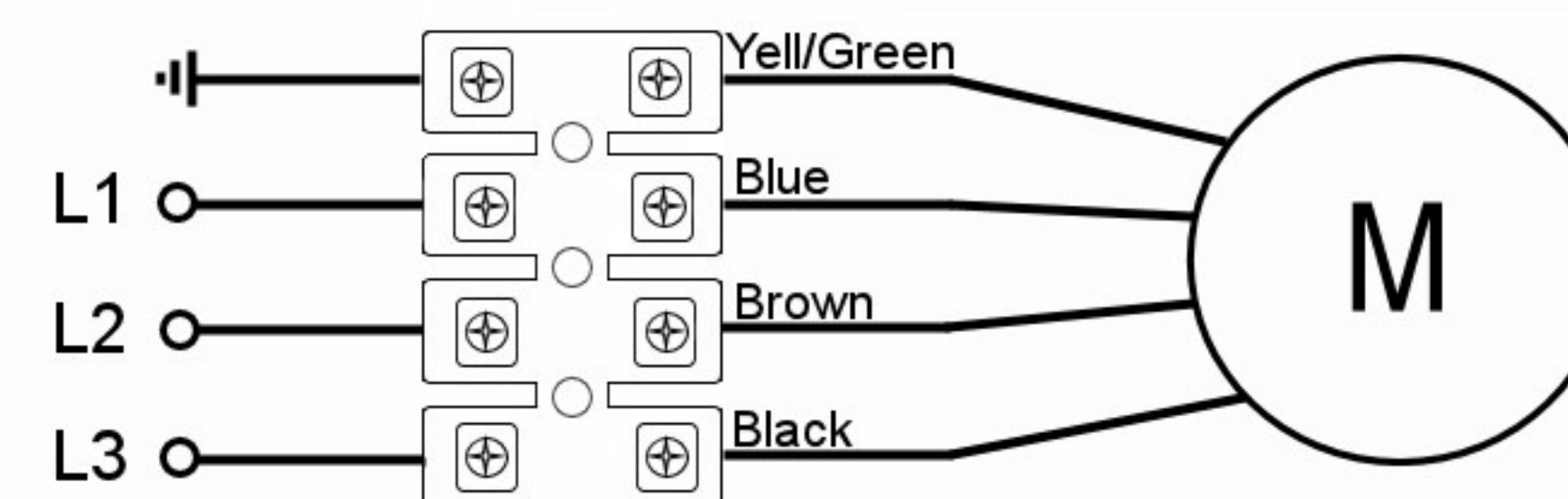

SPECIFICATION					
Motor	3ph	Speed (RPM)	1380	Bearings	Ball
Voltage (V)	380	Motor Protection	Th. Prot.	Weight (Kg)	5.7
Frequency (Hz)	50/60	Insulation Class	F	Air Volume (M³/h)	3800
Power In/Out (W)	180	Protection Class	IP54	Noise Level (dBA)	66
Current (A)	0.47	Temp. Range	-30 +60	Capacitor (MF)	N/A

POLE STAR
 PRODUCTS LIMITED

POLE STAR PRODUCTS LIMITED	
Product Code	
GMA3-400B4-1	
Projection	A4
Angle	Scale:
± 3°	Sheet: 1 of