

All measurements shown are +/- 2mm

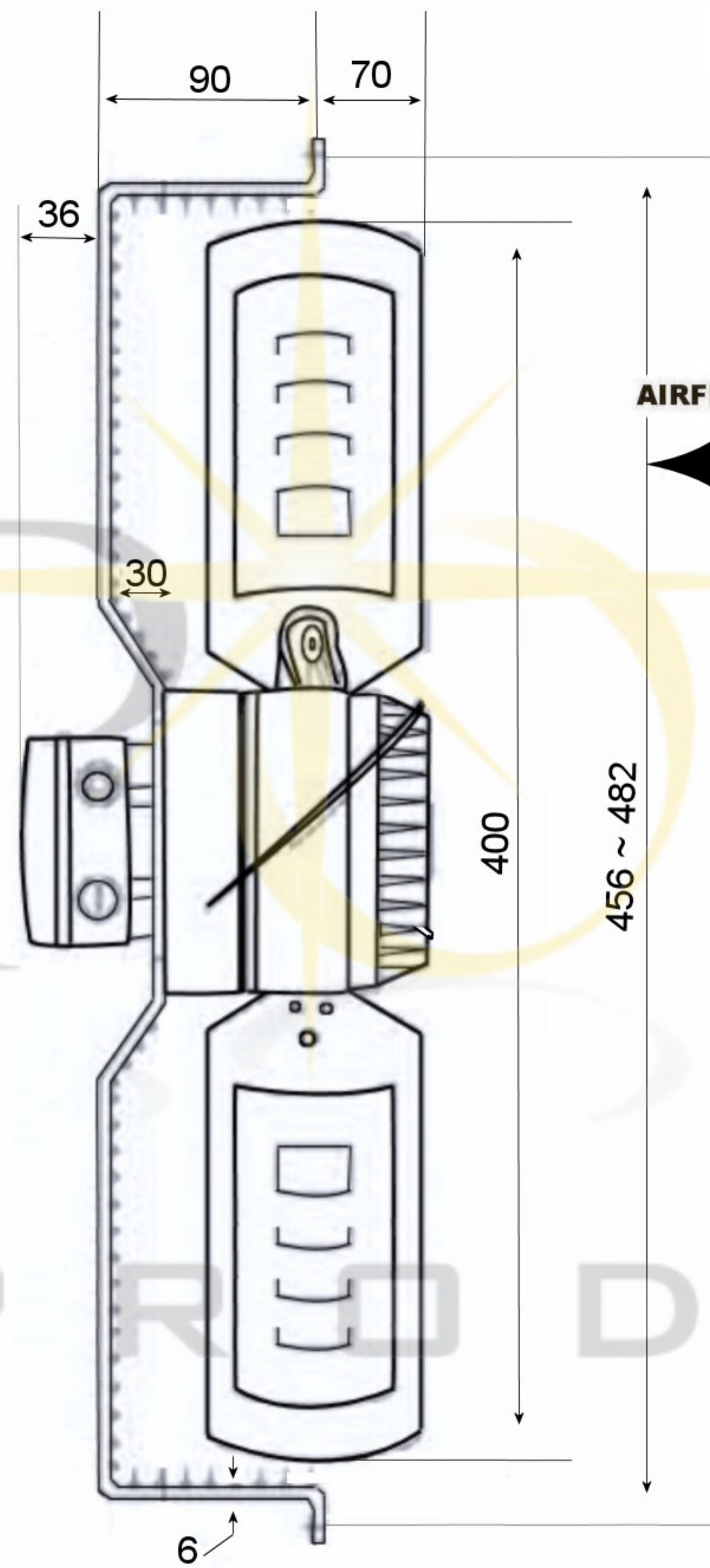

AIRFLOW DIRECTION
←

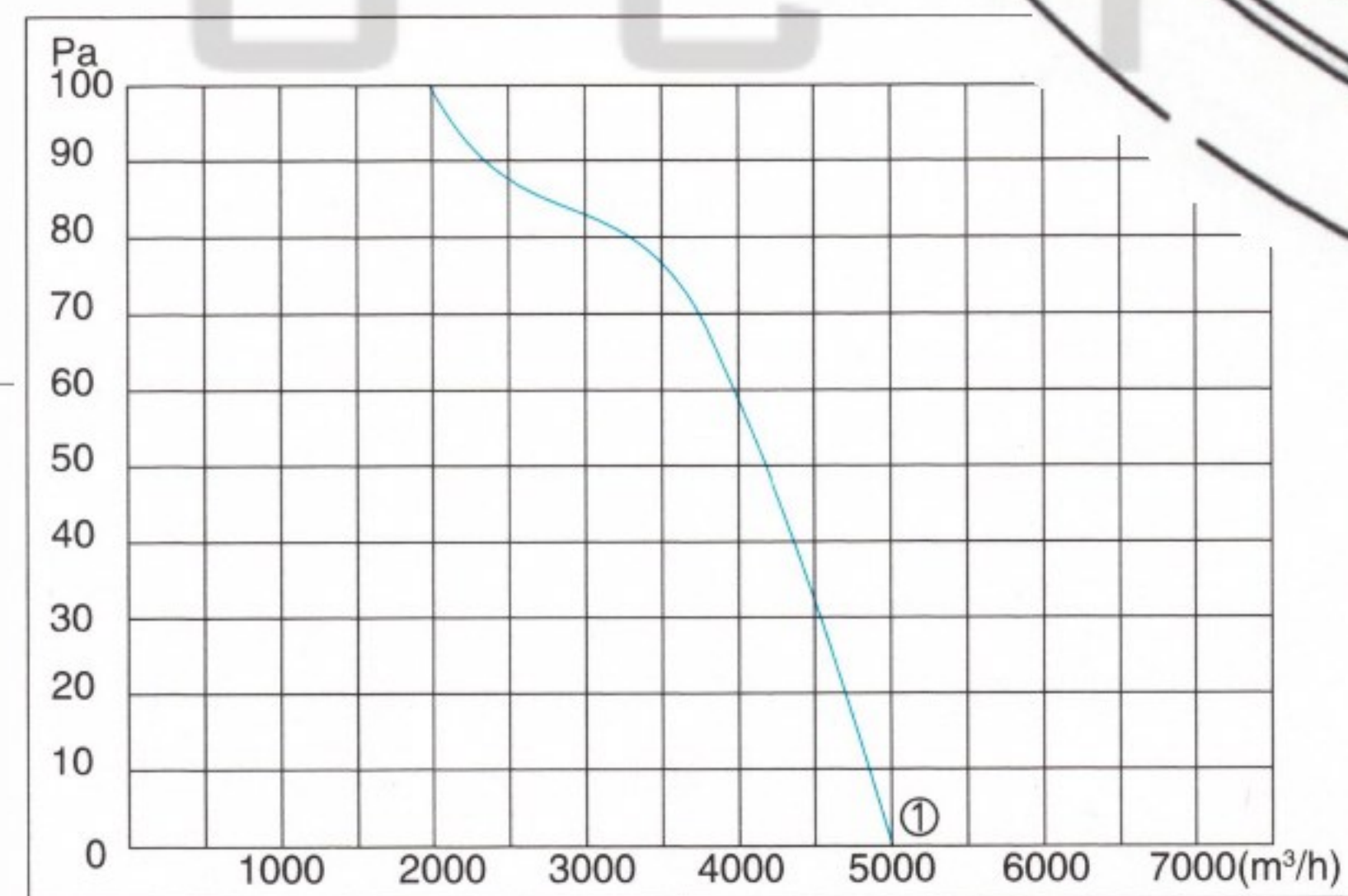
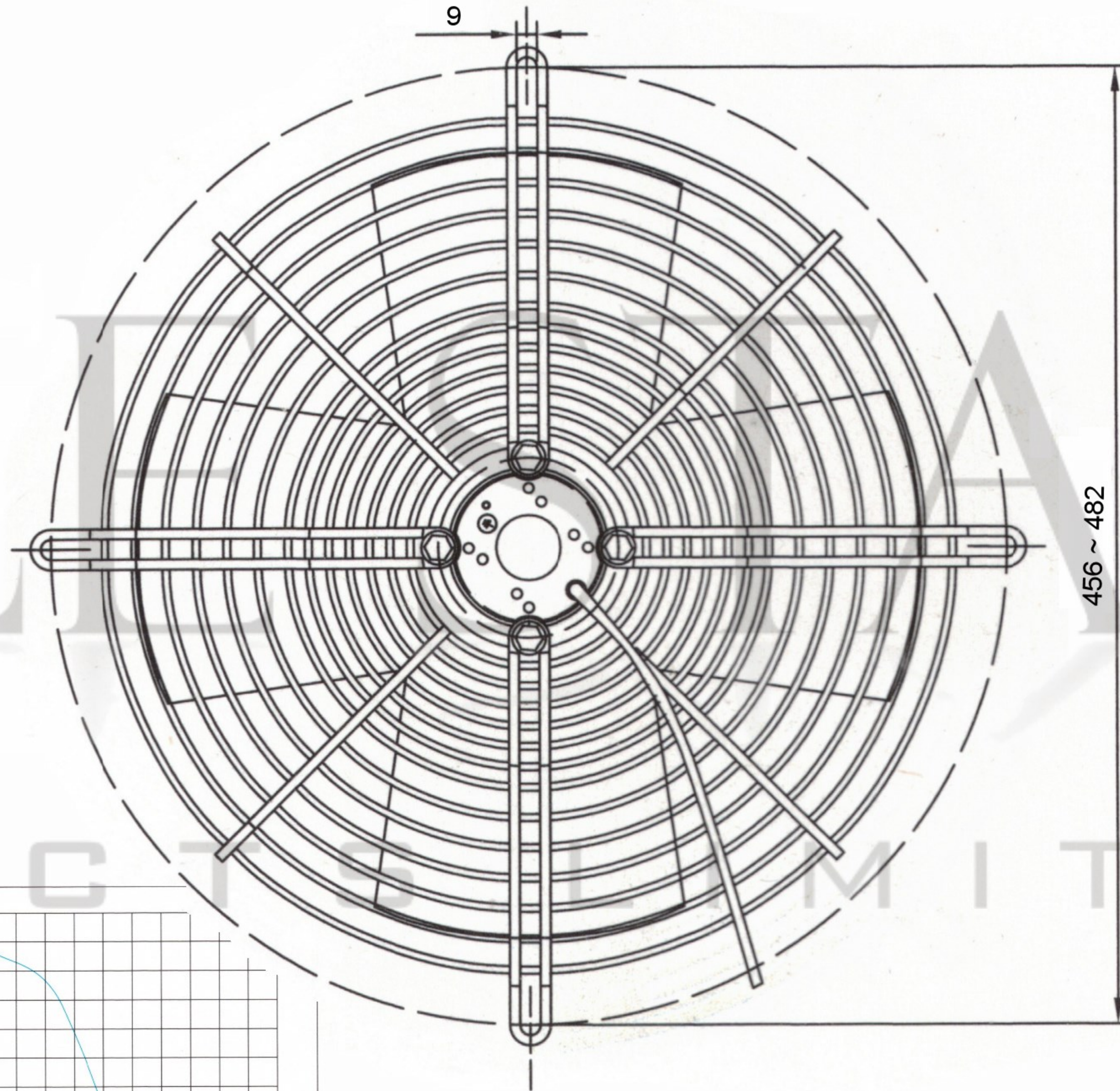

SPECIFICATION					
Motor	PSC	Speed (RPM)	1380	Bearings	Ball
Voltage (V)	220/240	Motor Protection	Th.Prot.	Weight (Kg)	6.0
Frequency (Hz)	50/60	Insulation Class		Noise dB(A)	68
Power In/Out (W)	240	Protection Class		Range (meters)	17
Current (A)	1.08	Capacitor (MF)		Air Volume (m3/h)	4100

POLE STAR
PRODUCTS LIMITED

POLE STAR PRODUCTS LIMITED	
Product Code	GMC1-400S4-1
Projection Angle	± 3°
	A4
	Scale:
	Sheet: 1 of