

All measurements shown are +/- 2mm

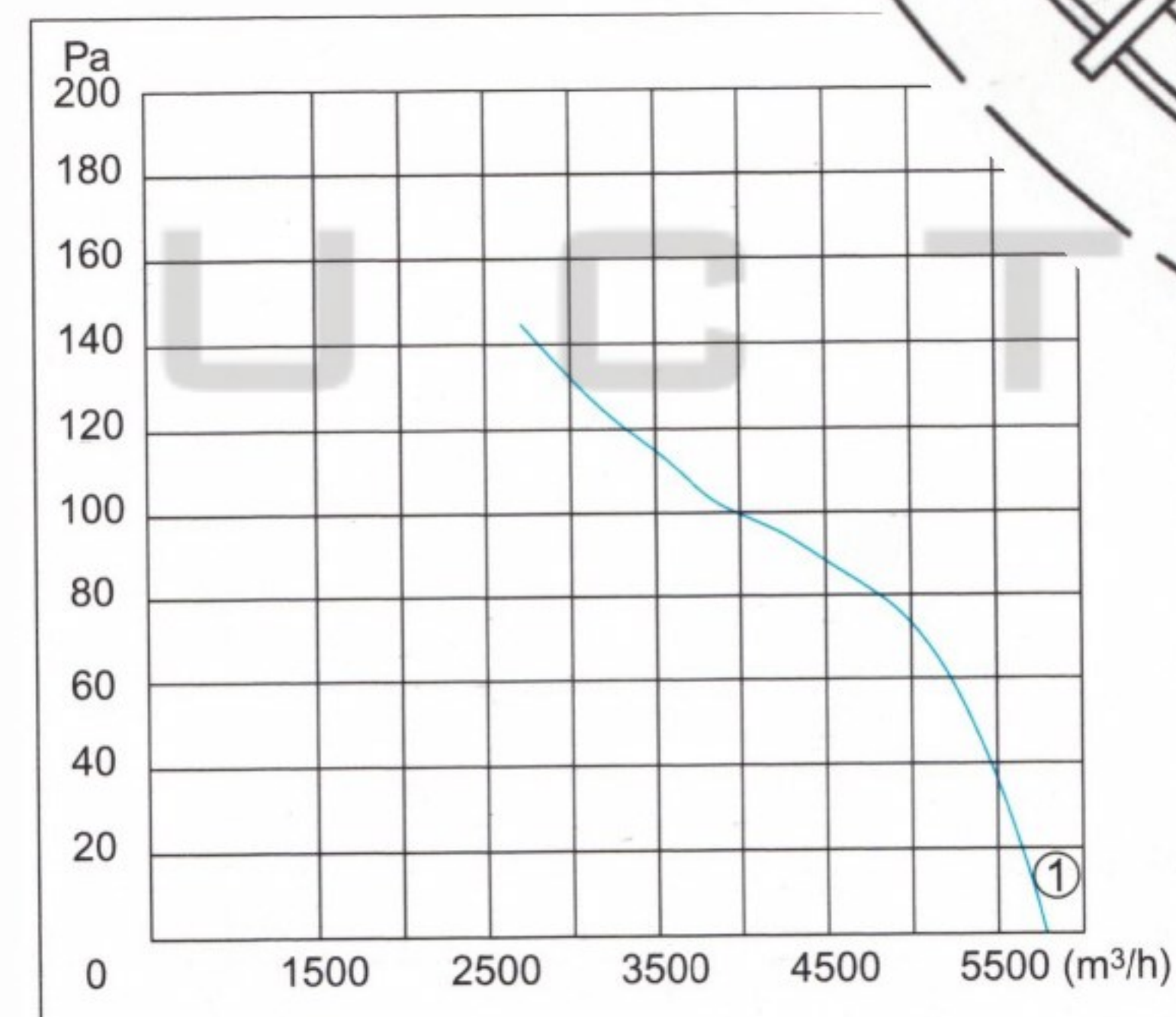
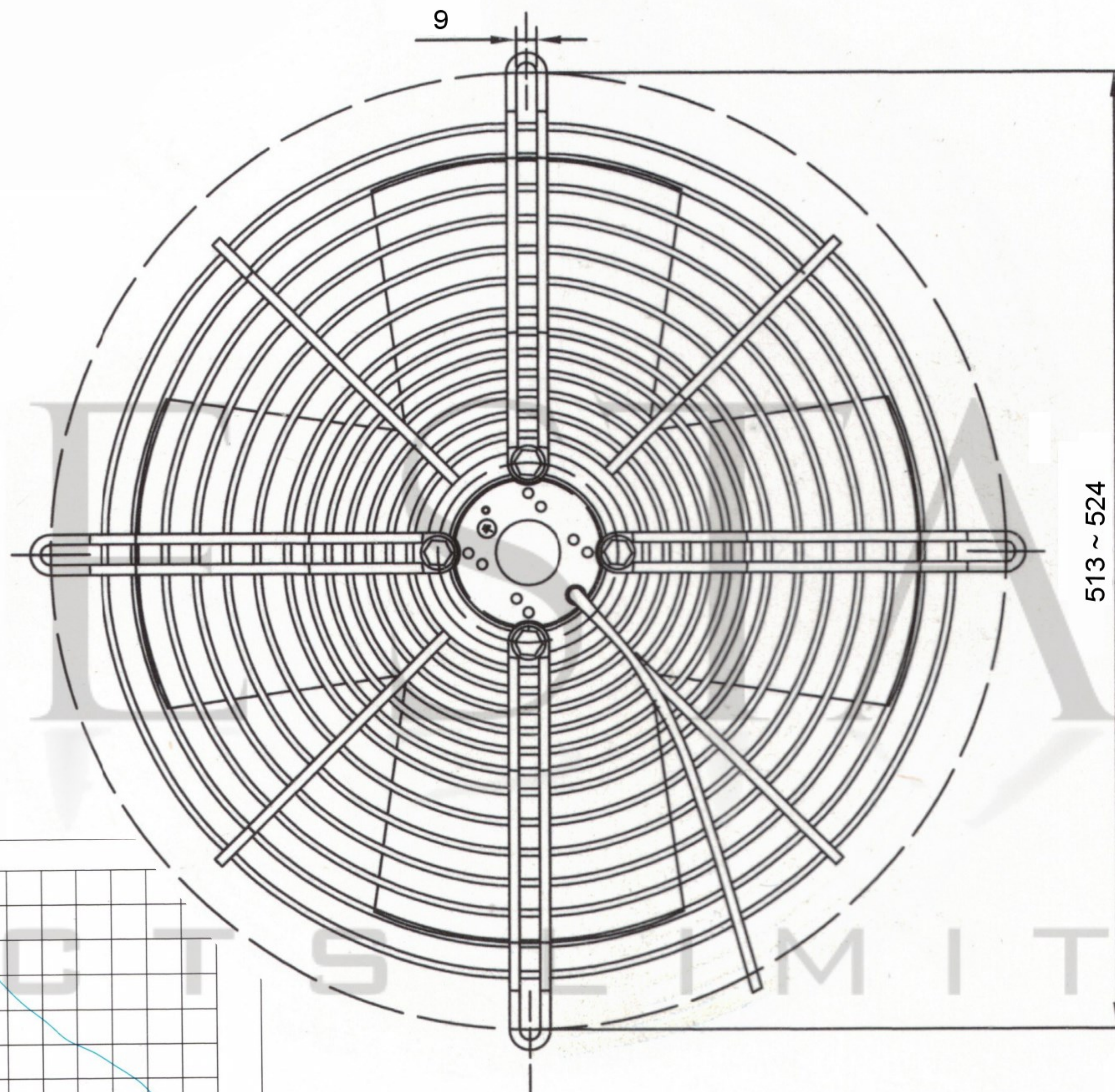
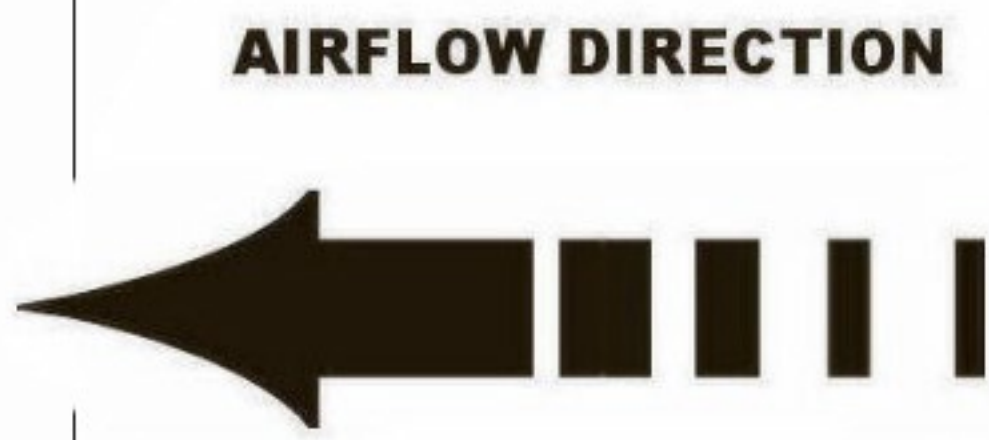
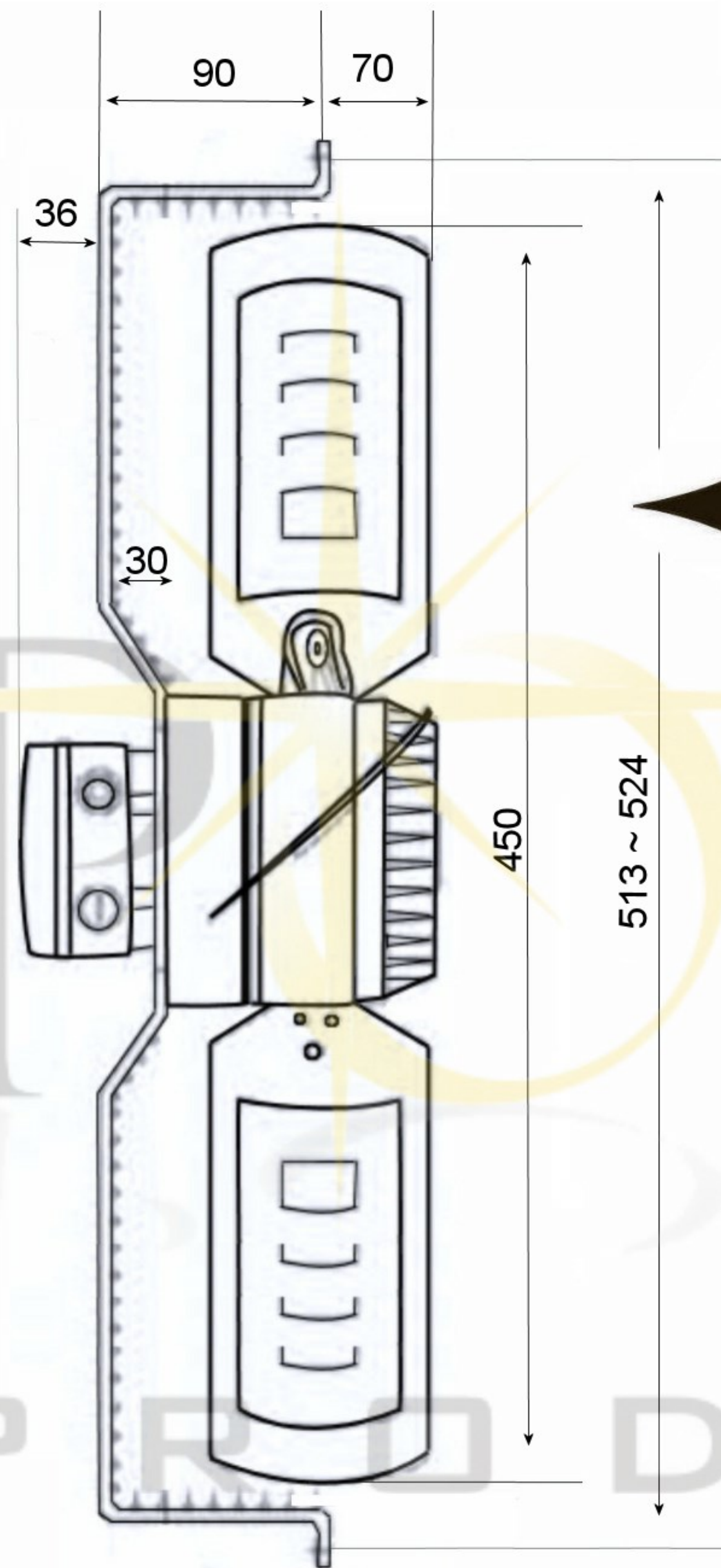

SPCIFICATION All sizes shown are in millimeters (mm) unless otherwise satated.

Motor	PSC	Speed (RPM)	1380	Bearings	Ball
Voltage (V)	220/240	Motor Protection	Th.Prot.	Weight (Kg)	8.0
Frequency (Hz)	50/60	Insulation Class		Noise dB(A)	69
Power In/Out (W)	520	Protection Class		Range (meters)	20
Current (A)	2.3	Capacitor (MF)		Air Volume (m3/h)	5750

POLE STAR
PRODUCTS LIMITED

POLE STAR PRODUCTS LIMITED	
Product Code GMC1-450S4-1	
Projection Angle ± 3°	A4
Scale: Sheet: 1 of	