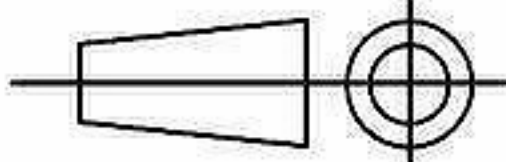

SPECIFICATION					
Motor	Spl/Ph	Speed (RPM)	1275	Bearings	Ball
Voltage (V)	230/240	Motor Protection	Th.Prot	Weight (Kg)	8.9
Frequency (Hz)	50	Insulation Class	B	Air Volume (M ³ /h)	
Power In/Out (W)	250	Protection Class	42	Noise Level (dBA)	
Current (A)	2.7	Capacitor (Mf)	N/A	Pressure (Pa)	

POLE STAR
PRODUCTS LIMITED

POLE STAR PRODUCTS LIMITED	
Product Code 60FM250R-4	
Projection Angle ± 3°	
A4	
Scale: Sheet: 1 of	