

		MM
A	Total Width	
B	Fixing Bracket Width	
C	Maximum Fixing Bolt Diameter	7.0
D	PCD	242
E	Minimum PCD	
F	Fan blade diameter	175
G	Basket diameter	195
I	Basket depth	46
J	Junction box protrusion	60
K	Fan blade/motor protrusion	12
L	Overall depth	58

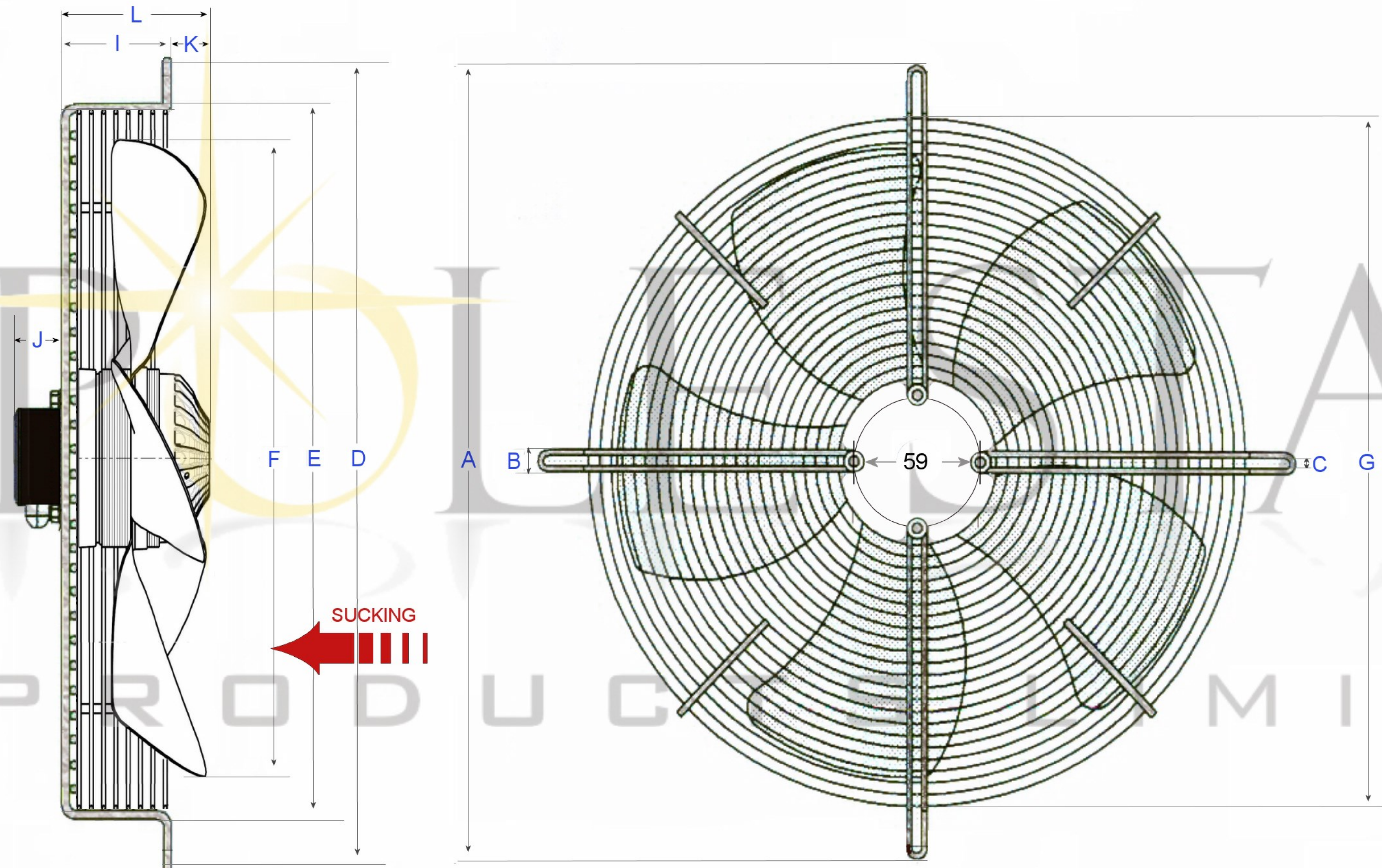

All measurements shown are in millimeters
 Measurements shown have manufacturing tolerances of +/- 2mm

SPECIFICATION					
Motor	PSC	Speed (RPM)	2600	Bearings	Ball
Voltage (V)	220/240	Motor Protection	Th. Prot.	Weight (Kg)	1.3
Frequency (Hz)	50/60	Insulation Class	F	Air Volume (M ³ /h)	475
Power In/Out (W)	27	Protection Class	IP54	Noise Level (dBA)	61
Current (A)	0.15	Temp. Range	-30 +60	Capacitor (MF)	1.5

POLE STAR
 PRODUCTS LIMITED

POLE STAR PRODUCTS LIMITED	
Product Code	GMA1-175S-1
Projection	A4
Angle	Scale:
± 3°	Sheet: 1 of