

Wheel Size: 190 x 45

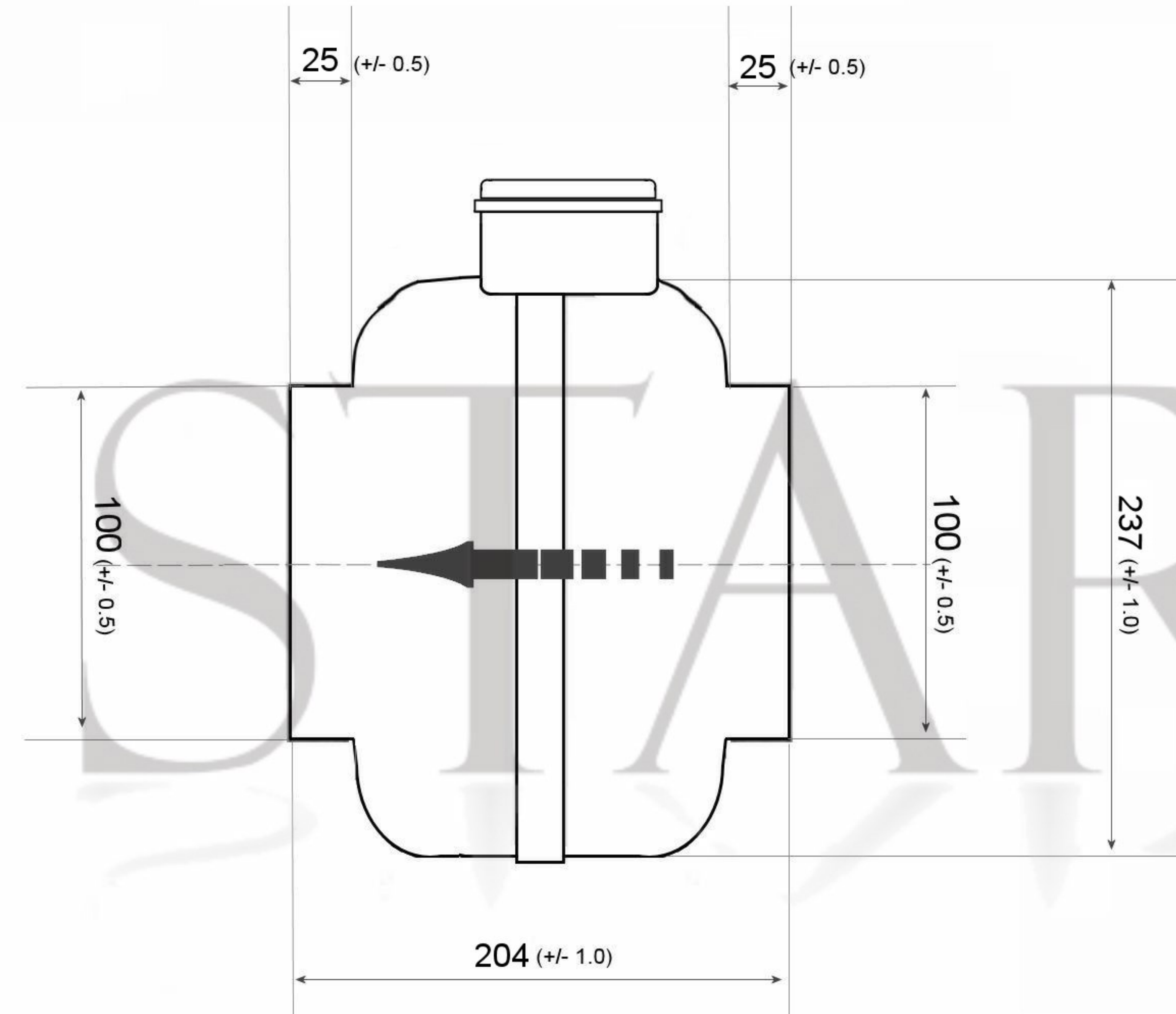

SPECIFICATION					
Motor	PSC	Speed (RPM)	2550	Bearings	Ball
Voltage (V)	220	Motor Protection	Th.Prot.	Weight (Kg)	3.0
Frequency (Hz)	50	Insulation Class	B	Volume M ³ /h	300
Power In/Out (W)	60	Protection Class	IP44	Static Pres. (Pa)	300
Current (A)	0.35	Capacitor (MF)	3.0	Noise (dBA)	47

All sizes in millimeters unless otherwise stated

POLE STAR
PRODUCTS LIMITED

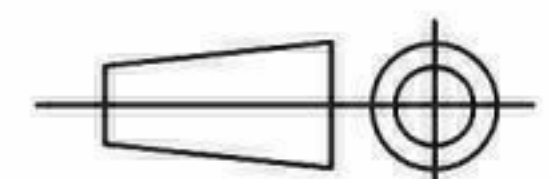
POLE STAR PRODUCTS LIMITED	
Product Code	ILDF2-100P
Projection Angle ± 3°	
Scale:	A4
Sheet:	1 of 1