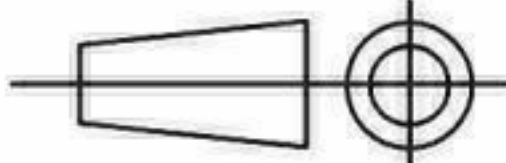

SPECIFICATION					
Motor	PSC	Speed (RPM)	2550	Bearings	Ball
Voltage (V)	220	Motor Protection	Th.Prot.	Weight (Kg)	5
Frequency (Hz)	50	Insulation Class	B	Volume M <sup>3</sup> /h	680
Power In/Out (W)	105	Protection Class	IP44	Static Pres. (Pa)	380
Current (A)	0.58	Capacitor (MF)	4.0	Noise (dBA)	52

All sizes in millimeters unless otherwise stated

**POLE STAR**  
PRODUCTS LIMITED

POLE STAR PRODUCTS LIMITED	
Product Code	<b>ILDF2-160P</b>
Projection Angle ± 3°	
Scale:	A4
Sheet:	1 of 1