

Wheel Size:

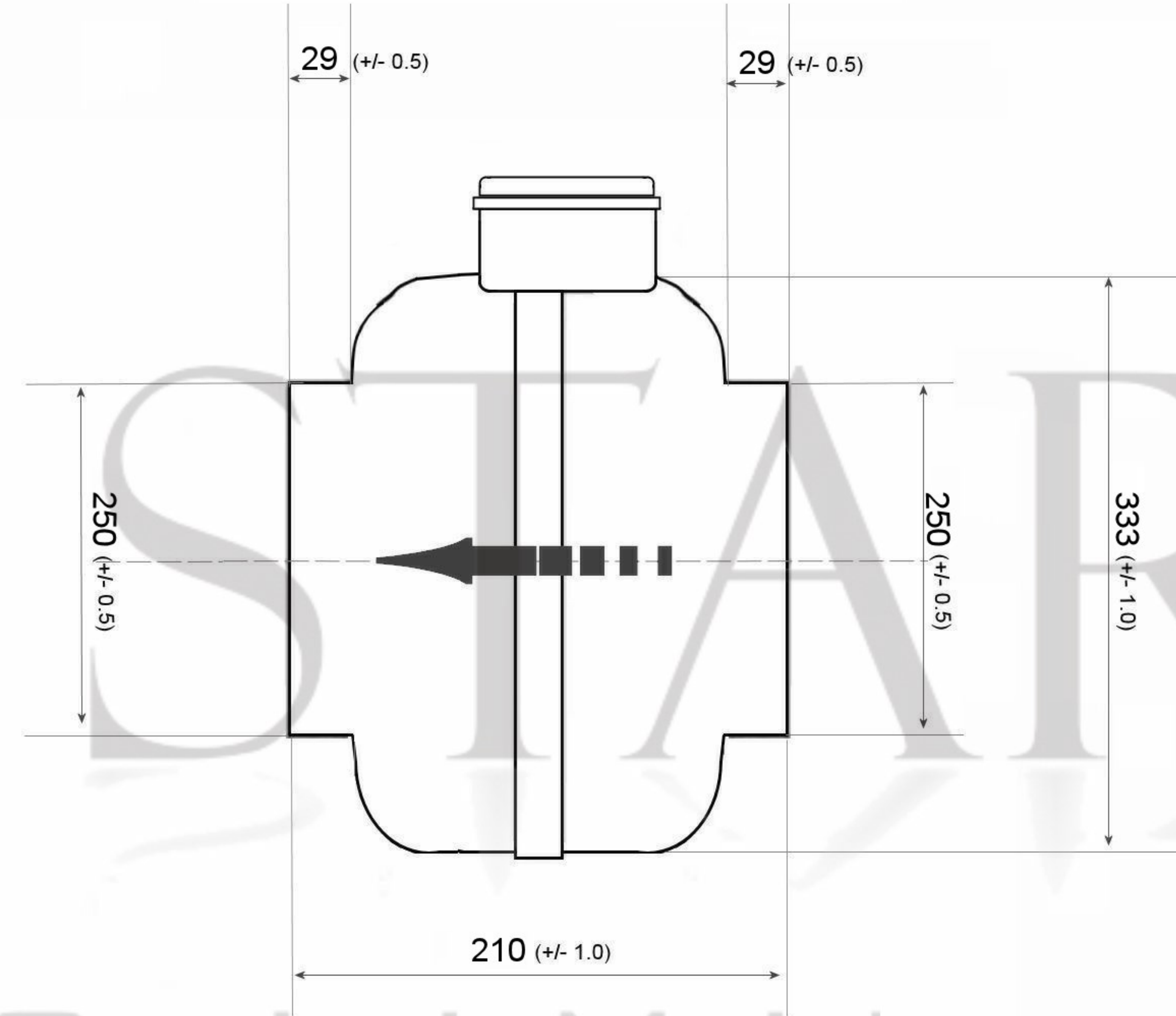

SPECIFICATION					
Motor	PSC	Speed (RPM)	2550	Bearings	Ball
Voltage (V)	220	Motor Protection	Th.Prot.	Weight (Kg)	6.0
Frequency (Hz)	50	Insulation Class	B	Volume M ³ /h	1100
Power In/Out (W)	158	Protection Class	IP44	Static Pres. (Pa)	490
Current (A)	0.8	Capacitor (MF)	6.0	Noise (dBA)	55

All sizes in millimeters unless otherwise stated

POLE STAR
PRODUCTS LIMITED

POLE STAR PRODUCTS LIMITED	
Product Code	ILDF2-250P
Projection Angle	± 3°
Scale:	A4
Sheet:	1 of 1