

Wheel Size: 280 x 50

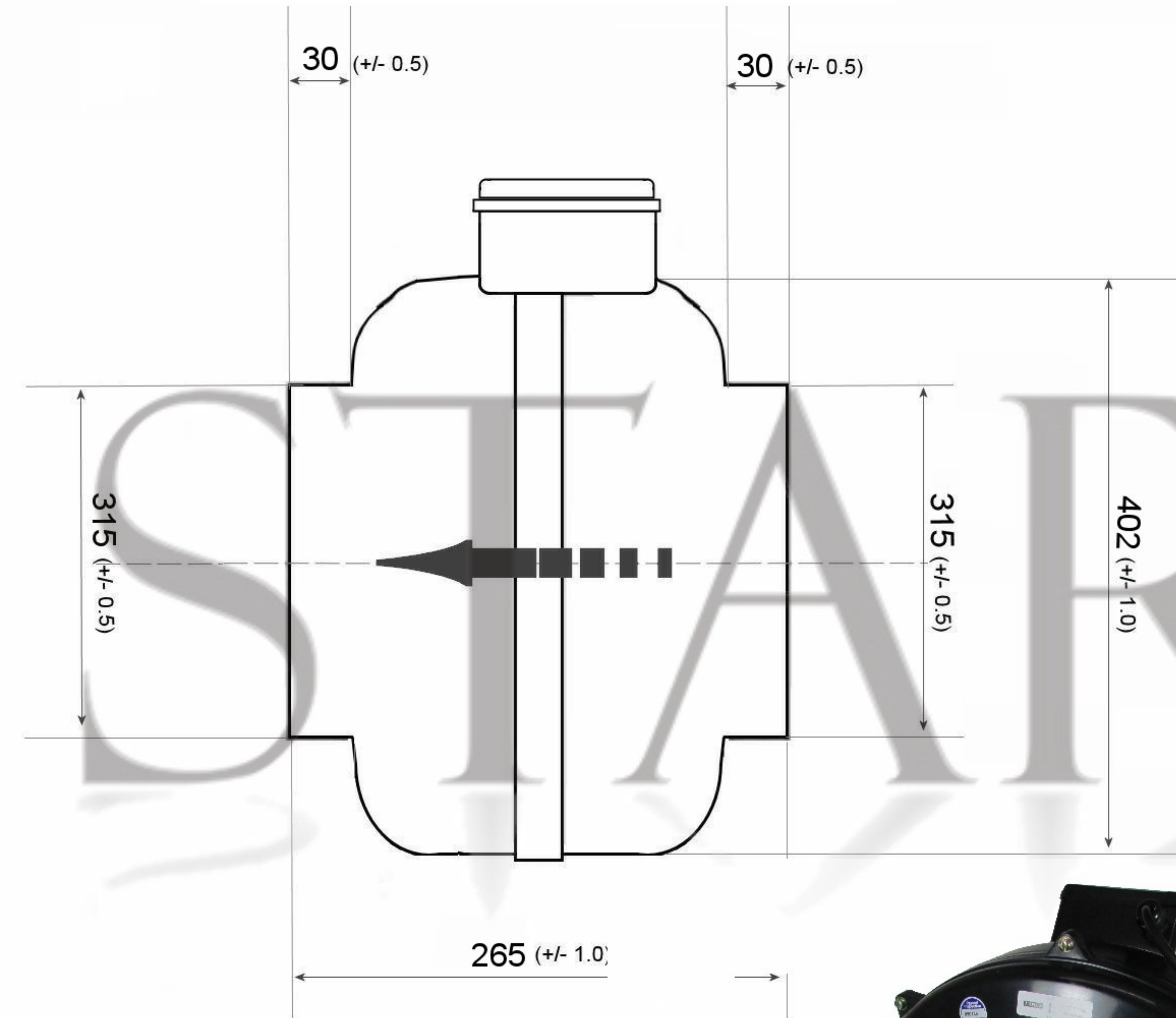

SPECIFICATION					
Motor	PSC	Speed (RPM)	2550	Bearings	Ball
Voltage (V)	220	Motor Protection	Th.Prot.	Weight (Kg)	8
Frequency (Hz)	50	Insulation Class	B	Volume M ³ /h	1700
Power In/Out (W)	220	Protection Class	IP44	Static Pres. (Pa)	710
Current (A)	1.05	Capacitor (MF)	6.0	Noise (dBA)	56

All sizes in millimeters unless otherwise stated

POLE STAR
PRODUCTS LIMITED

POLE STAR PRODUCTS LIMITED	
Product Code	ILDF2-315P
Projection Angle	± 3°
Scale:	A4
Sheet:	1 of 1