

Model shown is left hand motor

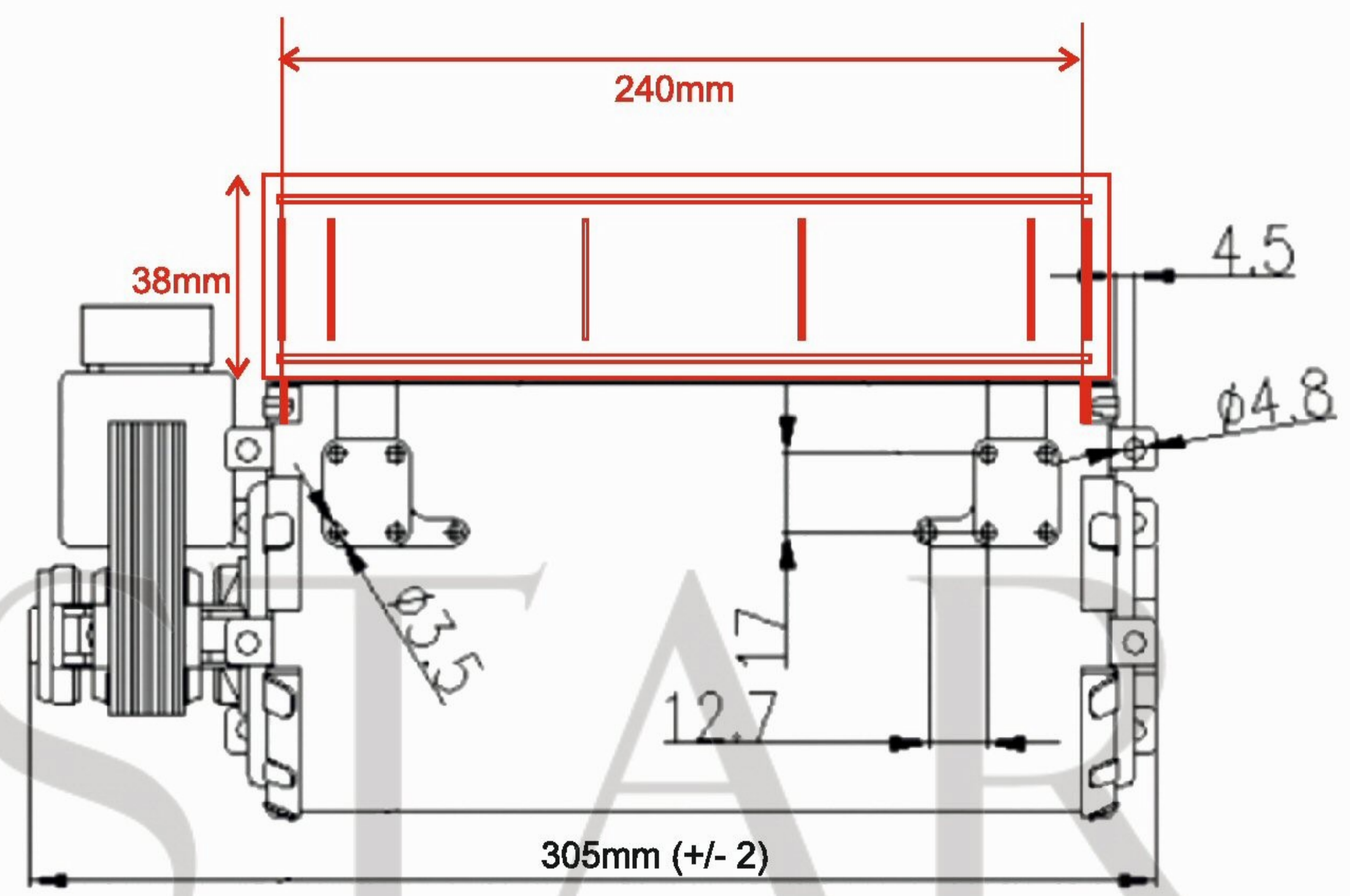

Fan Motor Mounting Positions

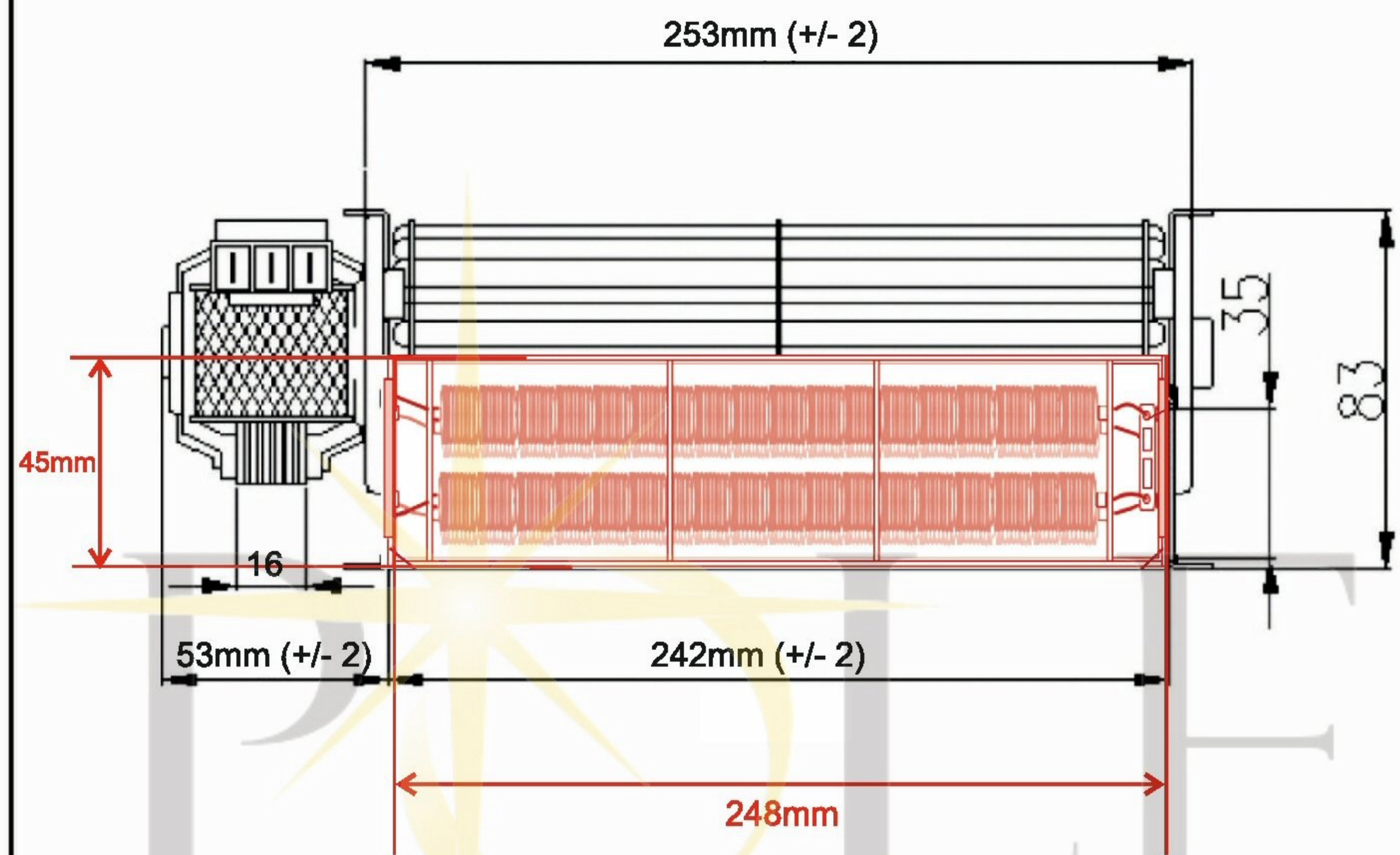
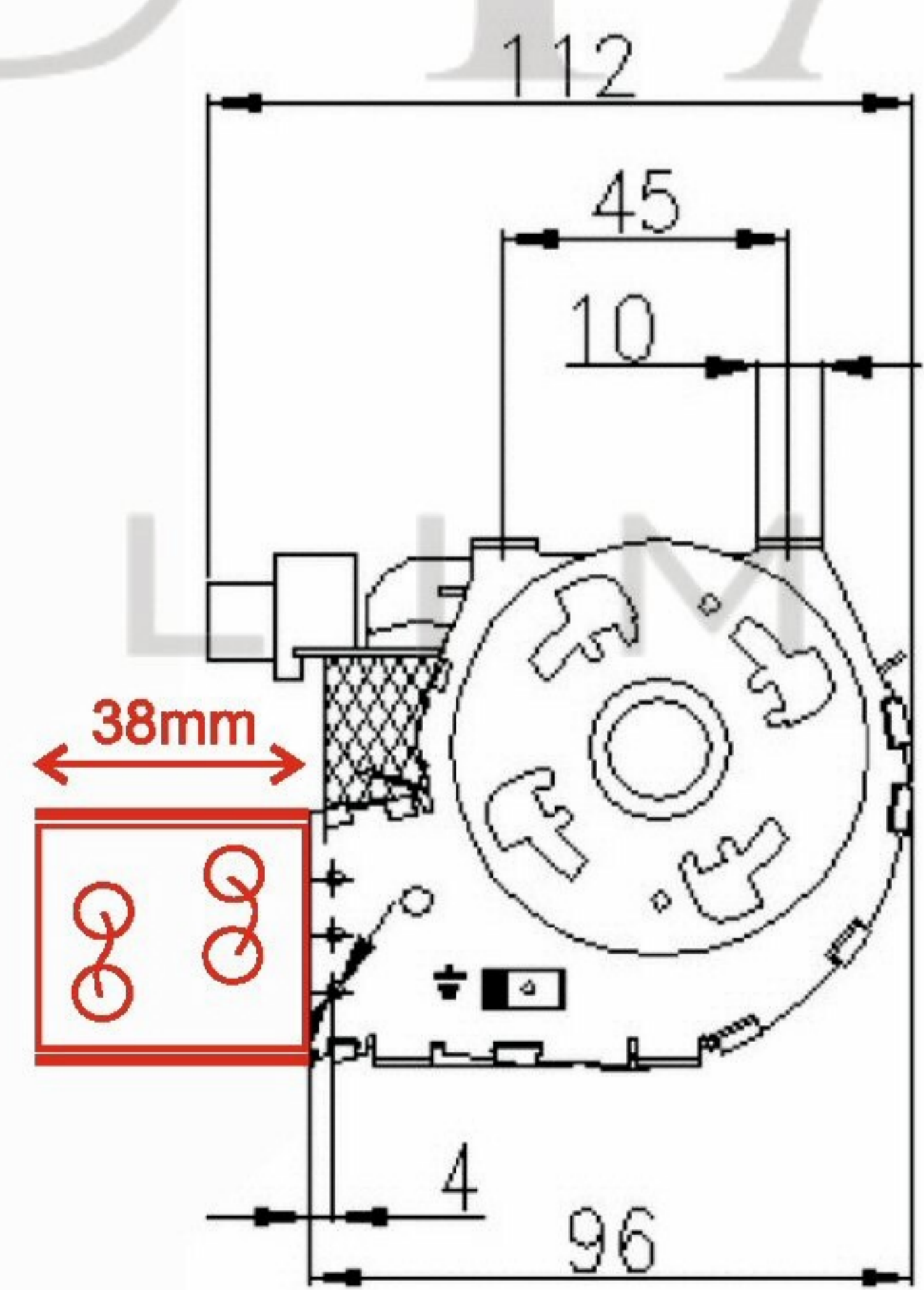
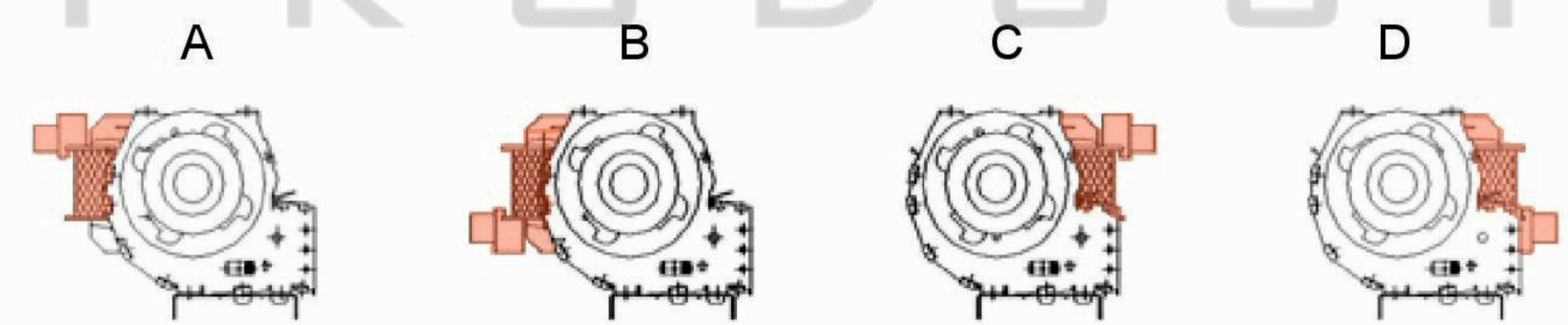

SPECIFICATION	Temp. Range: 0°C to + 60 °C		Heating element: 500+500 watts (1000w)		
Motor	SHP	Speed (RPM)	1300	Bearings	Sleeve
Voltage (V)	230/240	Motor Protection	Imp.Prot	Weight (Kg)	1.0
Frequency (Hz)	50	Insulation Class	F	Air Volume (M³/h)	160
Power In/Out (W)	28	Protection Class	IP20	Noise Level (dBA)	
Current (A)		Capacitor (Mf)	N/A	Max Pressure (Pa)	50

POLE STAR
PRODUCTS LIMITED

POLE STAR PRODUCTS LIMITED	
Product Code	
TAS24-HE-1A	
Projection Angle	± 3°
A4	
Scale:	
Sheet: 1 of	