

All measurements shown are in millimeters

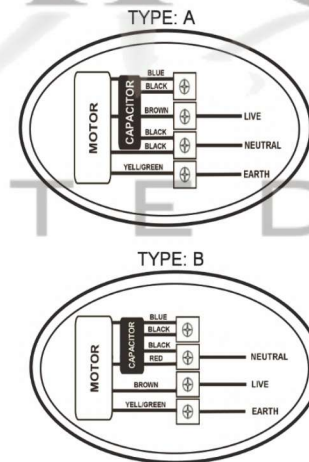

SPECIFICATION					
Motor	PSC	Speed (RPM)	1350	Bearings	Ball
Voltage (V)	220	Motor Protection	Th. Prot	Weight (Kg)	3.5
Frequency (Hz)	50	Insulation Class	B	Air Volume (M ³ /h)	1537
Power In/Out (W)	85	Protection Class	IP54	Noise Level (dBA)	60
Current (A)	0.45	Temp. Range	-30 +60	Capacitor (MF)	4.0

POLE STAR
PRODUCTS LIMITED

POLE STAR PRODUCTS LIMITED	
Product Code	GMA1-315B-1
Projection	A4
Angle	Scale:
± 3°	Sheet: 1 of