

Model shown is left hand motor

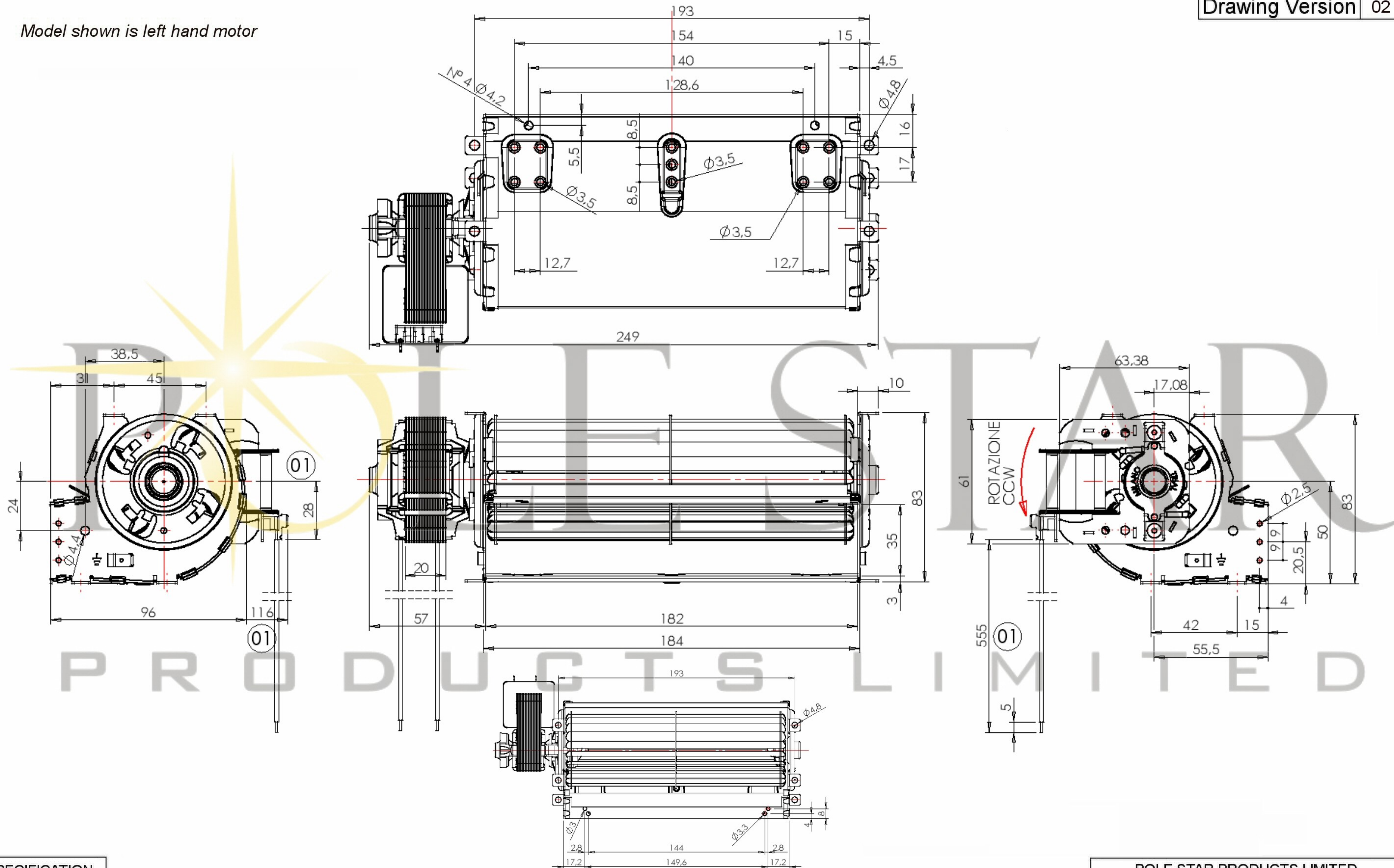

SPECIFICATION					
Motor	SHP	Speed (RPM)	1800	Bearings	Sleeve
Voltage (V)	230	Motor Protection	Imp.Prot	Weight (Kg)	0.9
Frequency (Hz)	50/60	Insulation Class	H	Air Volume (M³/h)	160
Power In/Out (W)	32	Protection Class	IP20	Max Ambient (°C)	90
Current (A)		Capacitor (Mf)	N/A	Max Pressure (Pa)	60

POLE STAR
PRODUCTS LIMITED

POLE STAR PRODUCTS LIMITED	
Product Code	THS18-16
Projection Angle	± 3°
Scale:	A4
Sheet:	1 of 1

